

99528 99529 99530

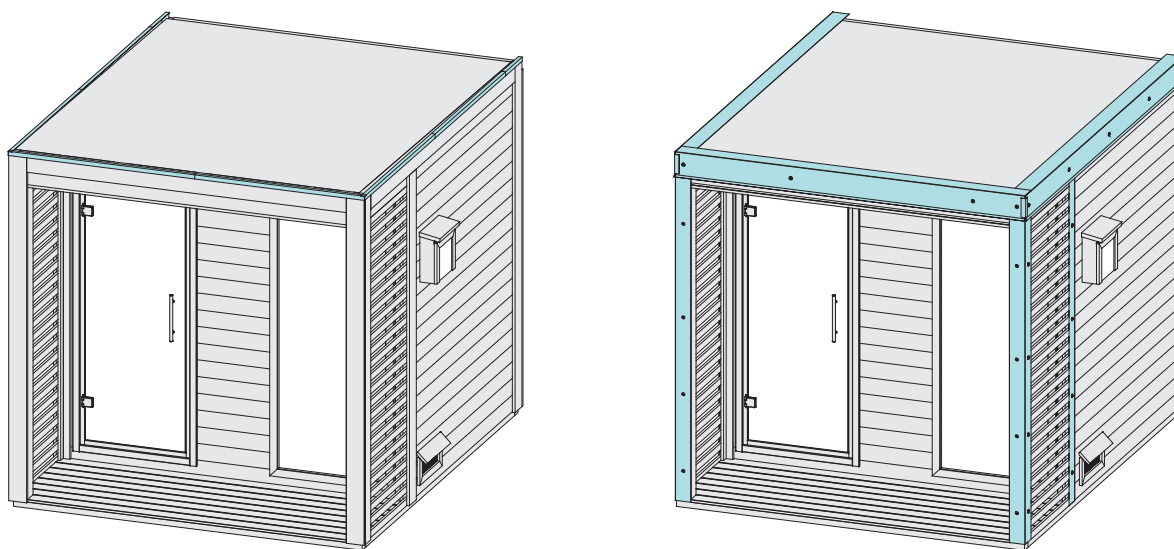

Das komplette
Farbangebot
finden Sie auf:



www.KARIBU-FARBENSHOP.de

-  **Aufbauanleitung**
-  **Building Instructions**
-  **notice de montage**
-  **montagehandleiding**
-  **Montagevejledning**
-  **Instrucciones de construcción**
-  **Istruzioni per il montaggio**
-  **Montážní návod**
-  **Navodila za sestavljanje**

Bitte bewahren Sie die Anleitung und den Garantieschein zur Seriennummer auf.

Vernichten Sie diese erst nach Ablauf der Garantiezeit.

Eventuelle Beanstandungen können mithilfe der Stückliste einfacher zugeordnet werden.

Beigelegte Dokumente

- Informationsheft
- Garantieschein zur Seriennummer
- Typenschild inkl. Warnhinweise (Sauna)
- ggf. Zubehör-Anleitungen in externen Paketen

*

-  Nicht im Lieferumfang enthalten
-  Not included
-  Non comprises dans la livraison
-  Niet bijgeleverd
-  No forman parte del suministro
-  Non incluso
-  V ceně není zahrnuto
-  Ikke inkluderet
-  Ni vključeno v obseg dobave









2

-  Nicht gebraucht
-  Not needed
-  Pas nécessaire
-  Niet nodig
-  No es necesario
-  Non necessario
-  Není nutná
-  Ikke nødvendigt
-  Ne uporablja se

4

-  Fixiert vorübergehend
-  Fixed temporarily
-  Temporairement fixe
-  Tijdelijk vast
-  Temporalmente fijo
-  Temporaneamente fisso
-  Dočasně pevný
-  Midlertidigt rettet
-  Začasno popravi

1

-  Länge muss ermittelt und zugesägt werden
-  Length must be determined and sawn
-  La longueur doit être déterminée et sciée
-  De lengte moet worden bepaald en worden gezaagd
-  La longitud debe ser determinada y aserrada
-  La lunghezza deve essere determinata e segata
-  Délka musí být určena a rozřezána
-  Længden skal bestemmes og saves
-  Določiti je treba dolžino in jo odrezati po velikosti.

3

-  Mit Zubehör
-  With accessories
-  Avec accessoires
-  Met toebehoren
-  Con accesorios
-  Con accessori
-  S příslušenstvím
-  Med tilbehør
-  Z dodatki

5

-  Bestand vom Haus
-  Inventory of the house
-  Inventaire de la maison
-  Inventaris van het huis
-  Inventario de la casa
-  Inventario della casa
-  Inventář domu
-  Inventar af huset
-  Inventarizacija hiše

Werkzeuge / Tools*

X

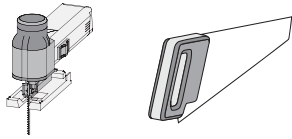

X

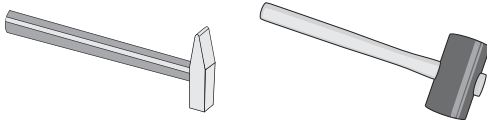

X

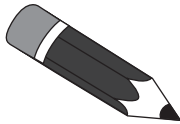

X

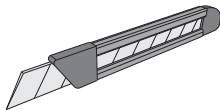
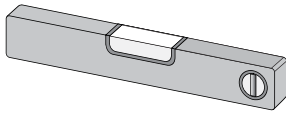

X

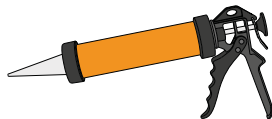
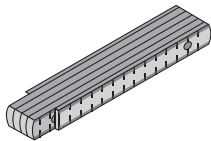

X

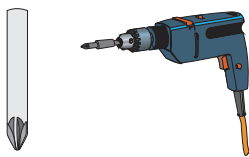

X

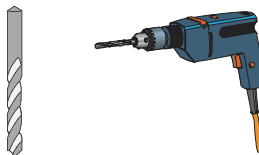

X

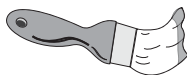

X





Technische Daten

In der Auftragsbestätigung bzw. Lieferschein ist der gekaufte Ofentyp bzw. das erworbene Steuergerät zu finden. Bitte entnehmen Sie die technischen Daten Ihrer Geräte der folgenden Auflistung

Gerät	Netzspannung	Wattage
Öfen		
9kW Ofen Bio	400V ~ 3N	9kW
9kW Ofen (Finnisch)	400V ~ 3N	9kW
9kW Ofen integr. Steuerung	400V ~ 3N	9kW
4,5kW Ofen Bio	400V ~ 3N	4,5kW
4,5kW Ofen (Finnisch)	400V ~ 3N	4,5kW
4,5kW Ofen integr. Steuerung	400V ~ 3N	4,5kW
3,6kW Ofen Bio	230V ~ 1N	3,6kW
3,6kW Ofen (Finnisch)	230V ~ 1N	3,6kW
3,6kW Ofen integr. Steuerung	230V ~ 1N	3,6kW
Steuergeräte		
externe Steuerung Easy Bio	400V ~ 3N	max. 10,8kW
externe Steuerung Plug&Play Bio	240V ~ 3N	max. 10,8kW
externe Steuerung (Finnisch)	400V ~ 3N	max. 10,8kW
externe Steuerung Plug&Play (Finnisch)	240V ~ 3N	max. 10,8kW
Multisteuergerät	400V ~ 3N	max. 10,5kW
externe Steuerung Classic Bio	400V ~ 3N	max. 9kW
externe Steuerung Classic (Finnisch)	400V ~ 3N	max. 9kW
externe Steuerung Premium Bio	400V ~ 3N	max. 12kW
externe Steuerung Premium (Finnisch)	400V ~ 3N	max. 9kW

 Vergleichen Sie zuerst die Material-liste mit Ihrem Paketinhalt! Bitte haben Sie Verständnis, dass Beanstandungen nur im nicht aufgebauten Zustand bearbeitet werden können!

 First compare the list of materials with your package contents! Please understand that complaints can be processed in the non-built status only!

 Commencez par comparer la liste du matériel avec le contenu de votre paquet! Sachez que nous traitons uniquement les réclamations concernant le matériel à l'état non monté!

 Vergelijk eerst de lijst van materialen met de inhoud van uw pakket! Reclamaties kunnen alleen in behandeling worden genomen zolang de onderdelen nog niet zijn gemonteerd!

 Start med at kontrollere materialelisten med indholdet af den leverede pakke! Vi gør venligst opmærksom på at reklamationer kun kan behandles for materialer som ikke er blevet bearbejdet!

 En primer lugar, compare la lista de material con el contenido del paquete. Rogamos entienda que las reclamaciones sólo pueden ser tramitadas antes de montar el objeto!

 Confrontate questa distinta materiali prima con il contenuto del pacchetto! Vi preghiamo di comprendere che eventuali reclami possono essere accolti solo prima del montaggio!

 Nejprve přezkontrolujte obsah balení podle materiálového listu! Mějte pochopení pro to, že případnou reklamaci se můžeme zabývat pouze tehdy, když díly nebudou smontované! Za pomoci tohoto seznamu můžete jednotlivé díly přiřadit k montážnímu návodu.

 Najprej primerajte zoznam materialov z vebino vašega paketa! Upoštevajte, da lahko pritožbe obravnavamo le v nesestavljenem stanju!





99528



99529



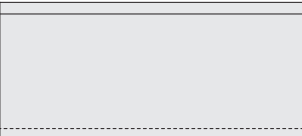

99530

	
2 x B1	1920 x 19 x 3 mm ID 20799
2 x B2	2156 x 90 x 16 mm ID 71514
4 x B3	390 x 45 x 18 mm ID 51434
50 x B4	804 x 45 x 18 mm ID 99794
2 x B5	2540 x 45 x 18 mm ID 16359
1 x B6	300 x 95 x 18 mm ID 19130
4 x B7	480 x 95 x 18 mm ID 20930
2 x B8	565 x 95 x 18 mm ID 15498
6 x B9	2070 x 95 x 18 mm ID 24216
1 x B10	2105 x 95 x 18 mm ID 1008
8 x B11	2235 x 95 x 18 mm ID 210
7 x B12	2195 x 140 x 26 mm ID 1009
6 x B13	2105 x 38 x 28 mm ID 30977
4 x B14	60 x 36 x 36 mm ID 5512
2 x B15	1870 x 78 x 38 mm ID 99487
2 x B16	2068 x 78 x 38 mm ID 98465
2 x B17	2260 x 60 x 40 mm ID 70614
6 x B18	2595 x 60 x 40 mm ID 51900
7 x B19	2300 x 45 x 45 mm ID 99512

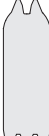
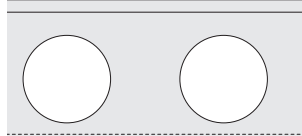
	
1 x W1	165 x 121 x 38 mm ID 99489
17 x W2	482 x 121 x 38 mm ID 1011
1 x W3	1397 x 121 x 38 mm ID 35381
37 x W4	1845 x 121 x 38 mm ID 70465
26 x W5	2195 x 121 x 38 mm ID 70501
2 x W6	2650 x 121 x 38 mm ID 70229

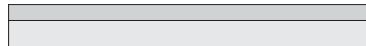

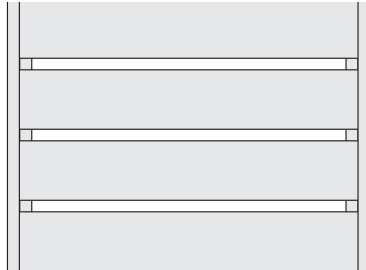
	
1 x W7	2195 x 121 x 38 mm ID 4164

	
2 x H1	555 x 45 x 45 mm ID 40301
2 x H2	1100 x 45 x 45 mm ID 40302

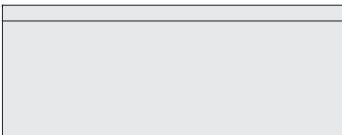
	
	
2 x L1	2156 x 550 x 95 mm ID 52068

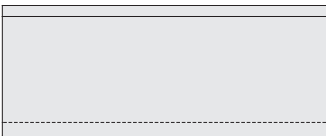
	
2 x G1	2000 x 58 x 17 mm ID 48545
2 x G2	400 x 95 x 18 mm ID 27167

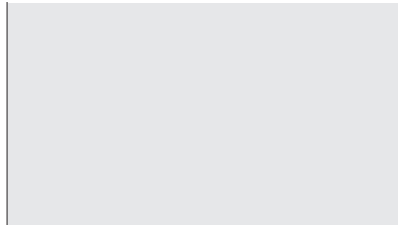
	
21 x R1	2195 x 96 x 19 mm ID 65729
26 x R2	2650 x 96 x 19 mm ID 63990

	
	
1 x M1	1839 x 349 x 55 mm ID 53731
2 x M2	1839 x 918 x 55 mm ID 21121

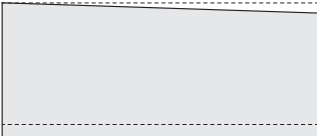
	
1 x V1	2650 x 96 x 38 mm ID 80908
1 x V2	2650 x 96 x 38 mm ID 80909

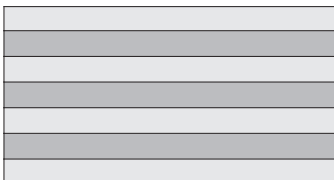
	
1 x K1	1820 x 140 x 26 mm ID 26480

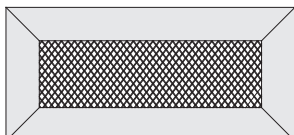
	
2 x T1	ID 86726

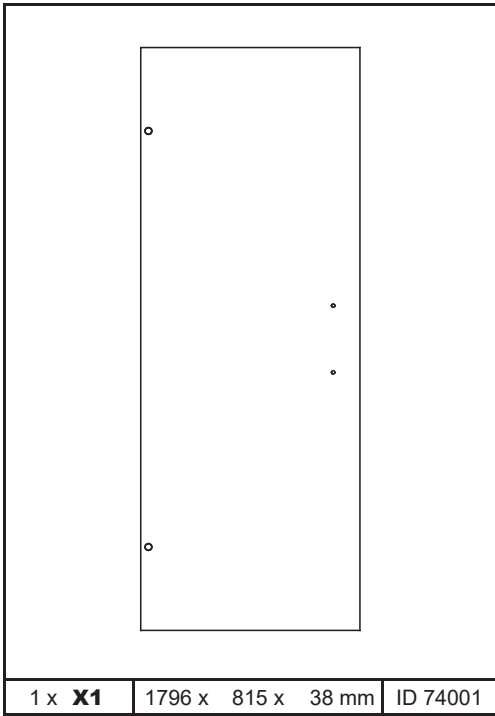

1 x **X1** | 1796 x 815 x 38 mm | ID 74001

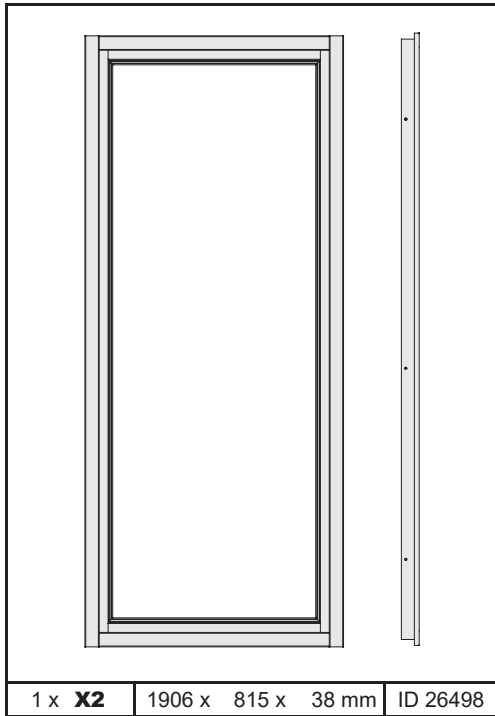

1 x **X2** | 1906 x 815 x 38 mm | ID 26498

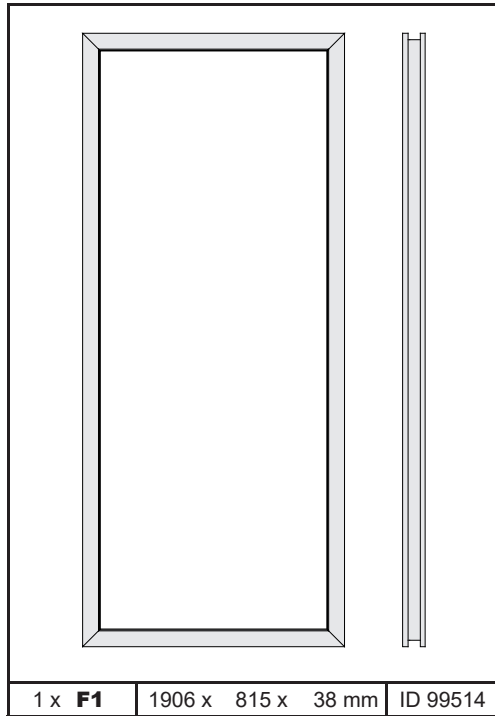

1 x **F1** | 1906 x 815 x 38 mm | ID 99514

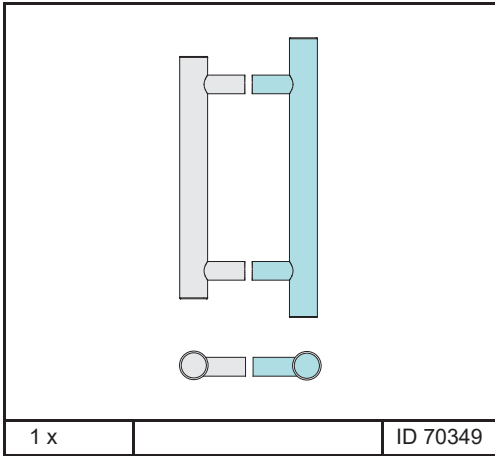

1 x | | ID 70349

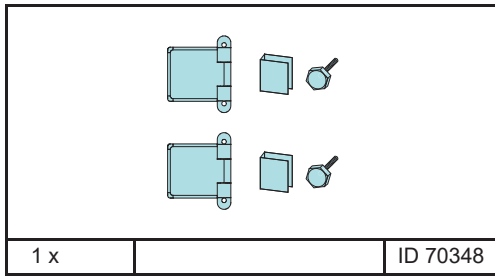

1 x | | ID 70348

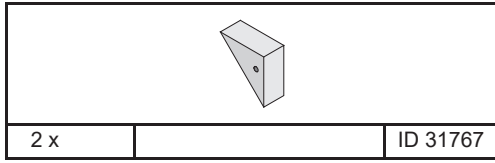

2 x | | ID 31767

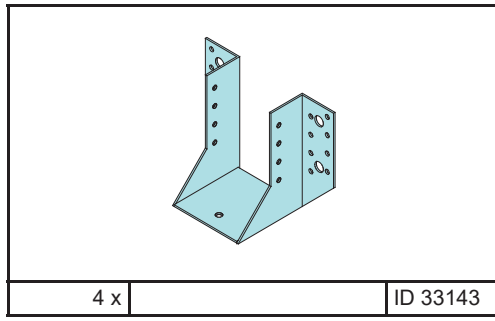

4 x | | ID 33143

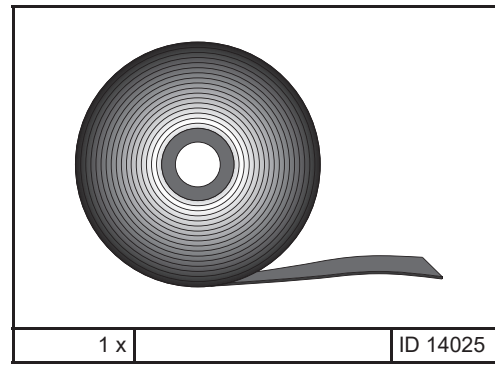
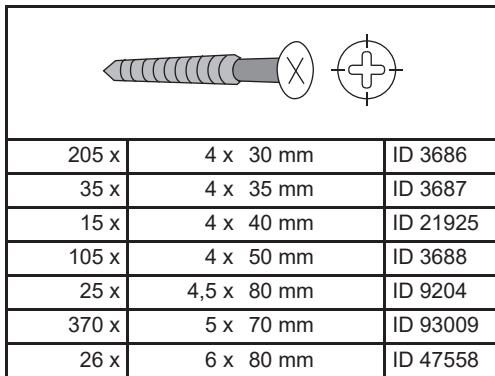

1 x | | ID 14025

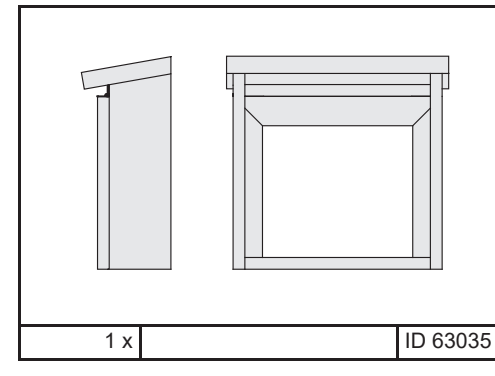

1 x | | ID 63035

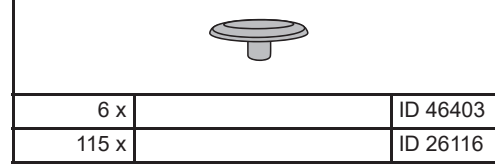
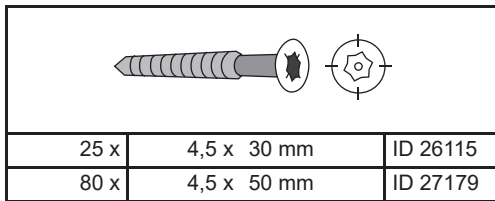

6 x | | ID 46403
115 x | | ID 26116

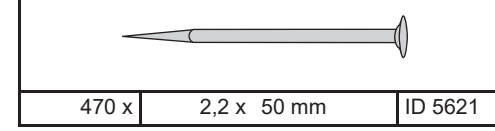

470 x | 2,2 x 50 mm | ID 5621

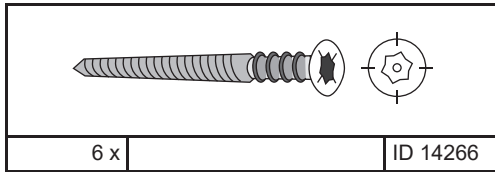

6 x | | ID 14266

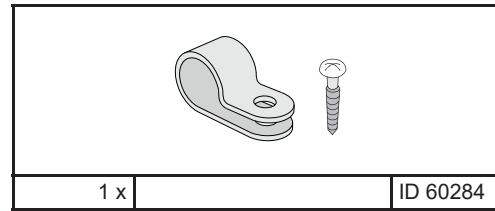

1 x | | ID 60284

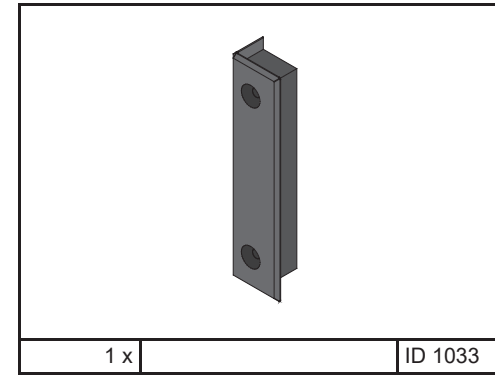

1 x | | ID 1033

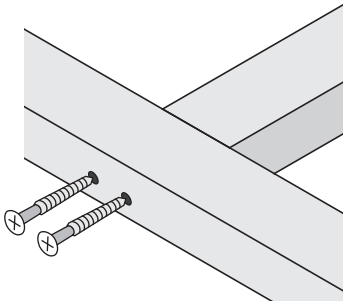
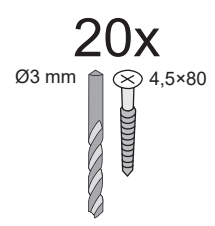
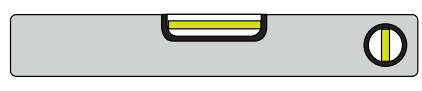

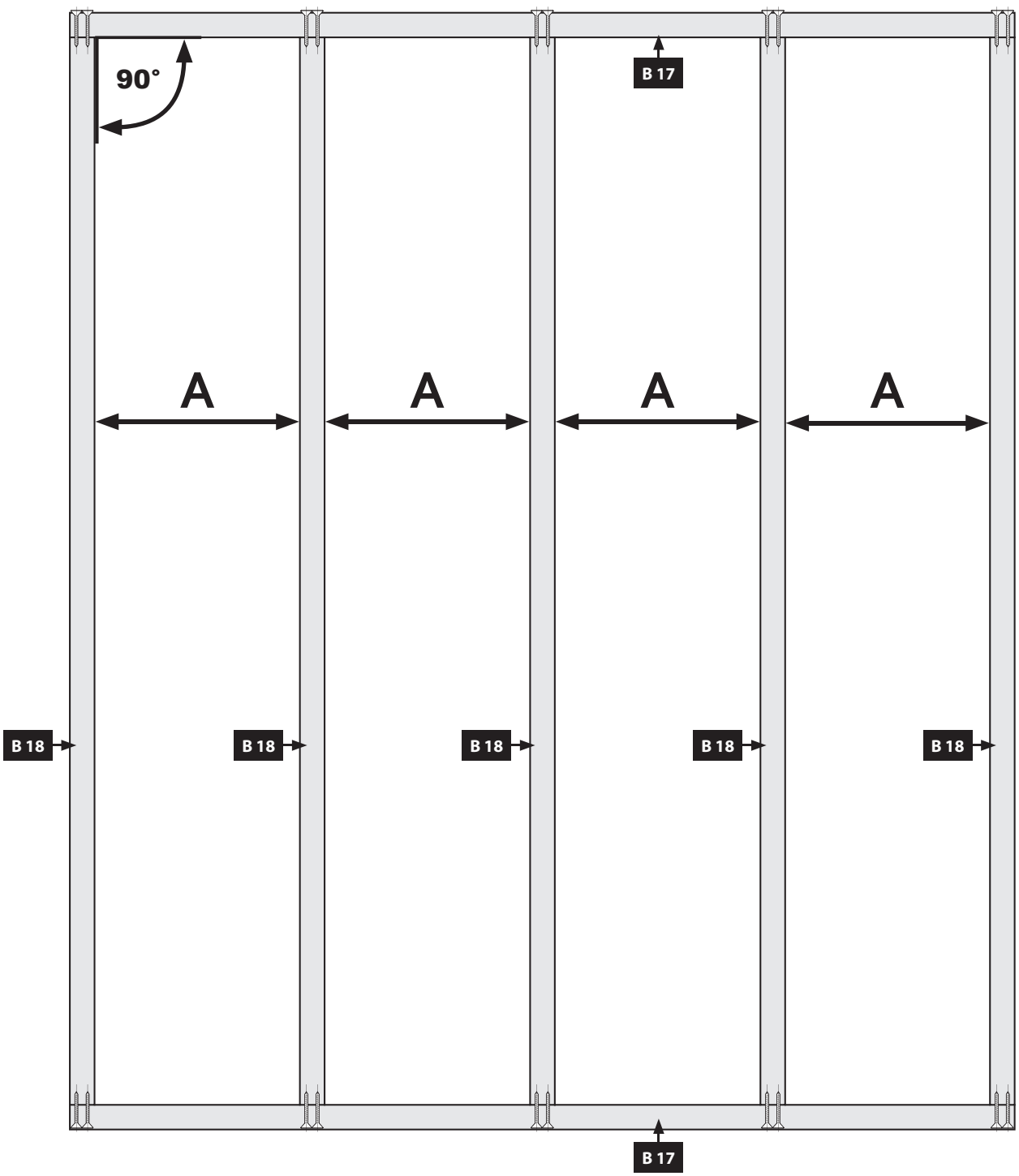
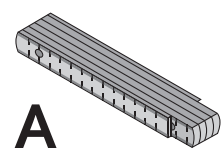

A = A

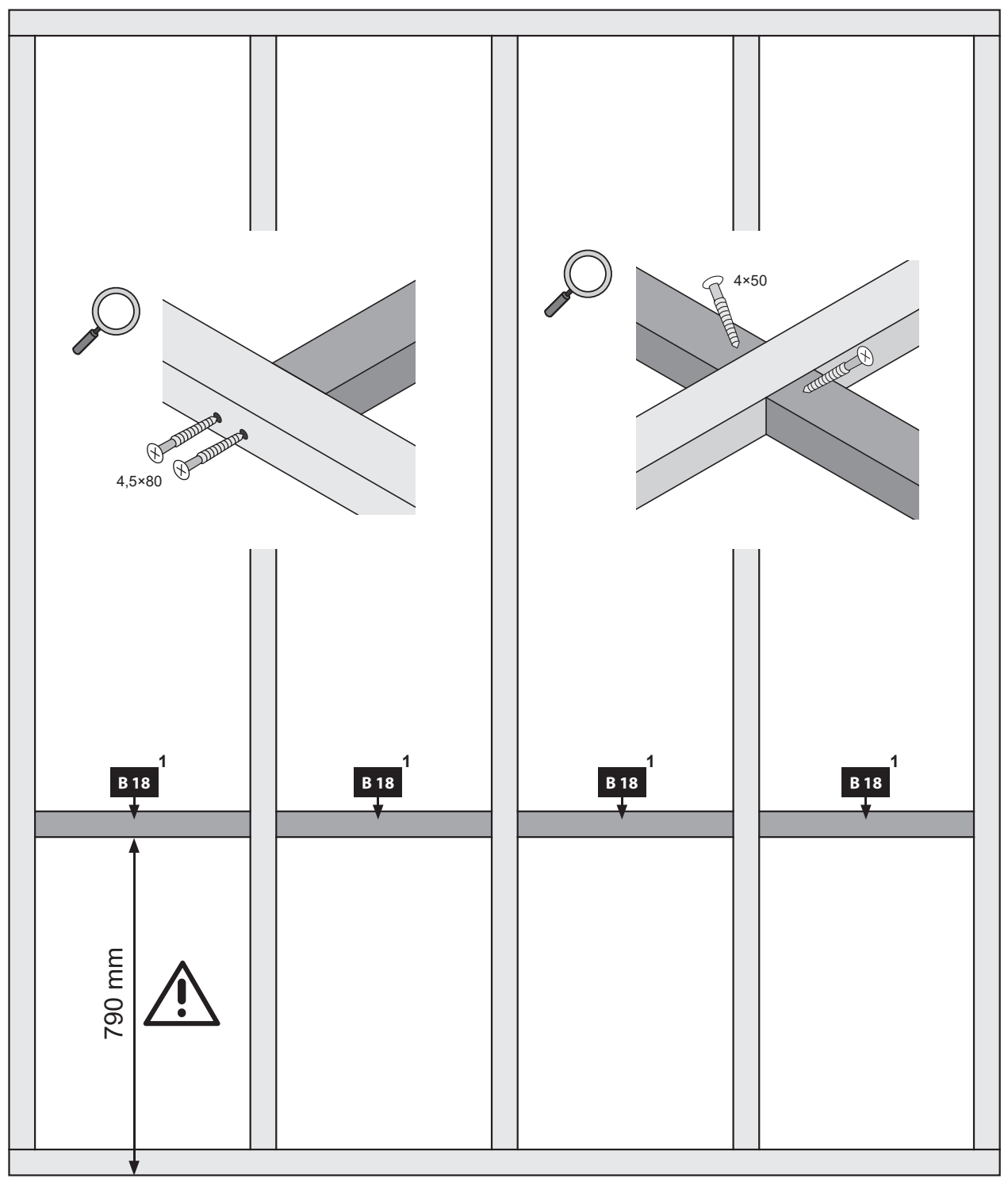
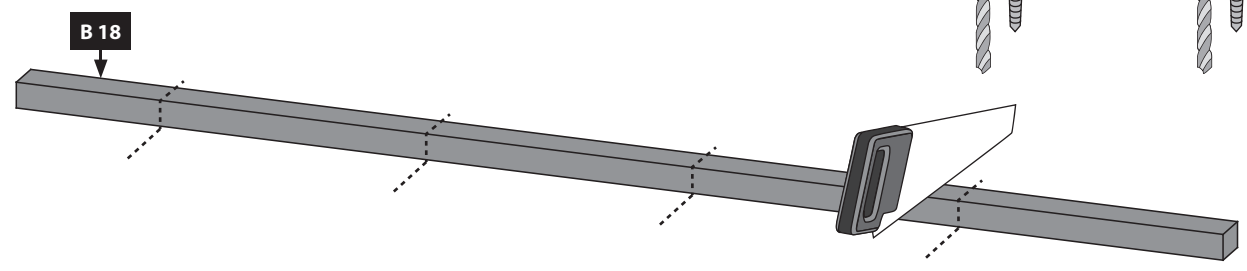
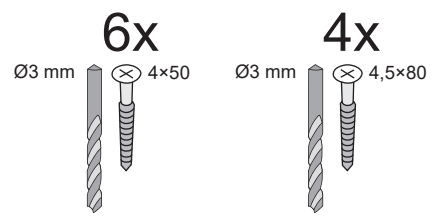

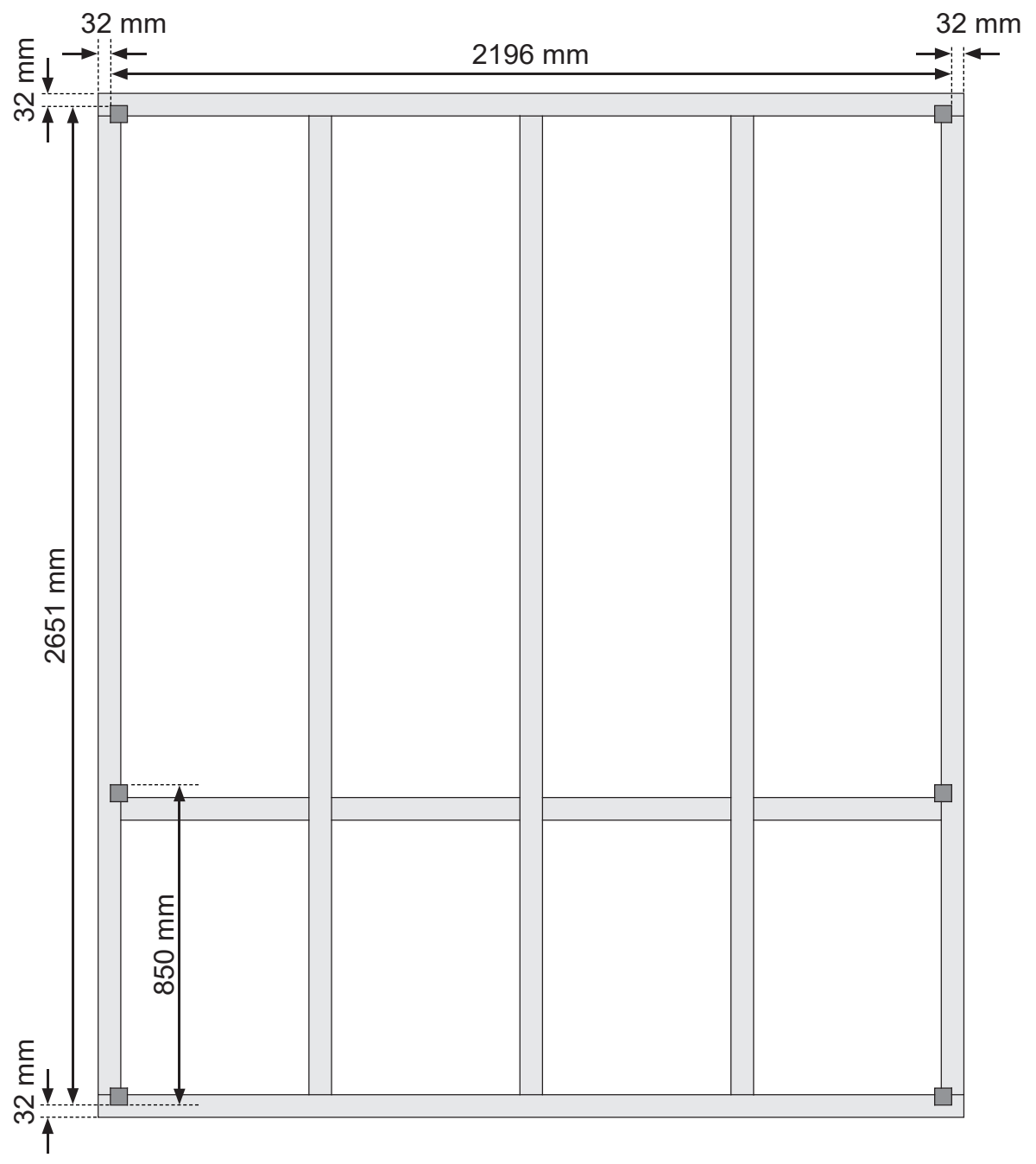
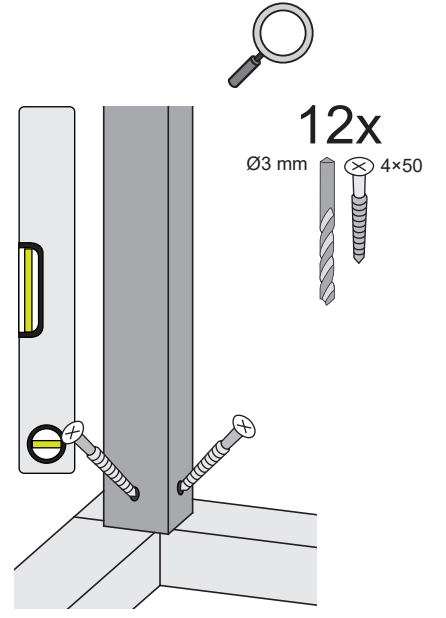
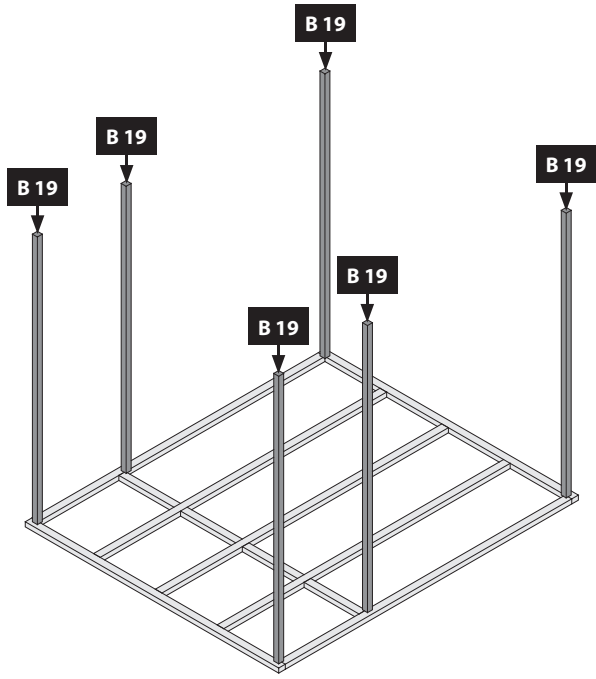





 Leim! Achten Sie auf die gleiche Höhe

 Glue! Look for the same height

 Colle! Faites attention à la même hauteur

 Lijm! Besteed aandacht aan de dezelfde hoogte

 Lim! Vær opmærksom på samme højde

 Pegamento! Prestar atención a la misma altura

 Colla! Prestare attenzione alla stessa altezza

 Klíč! Dávejte pozor na stejnou výšku

 Lepilo! Prepričajte se, da je višina enaka

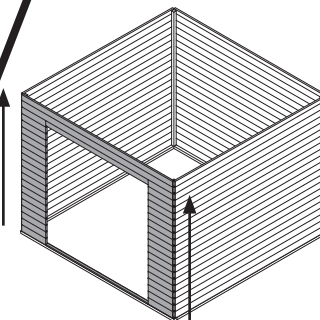
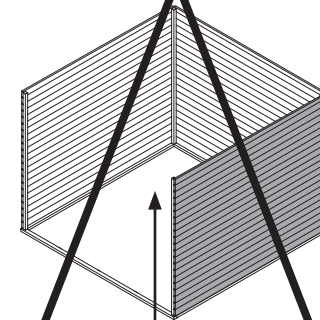
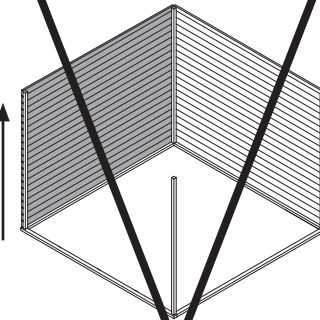
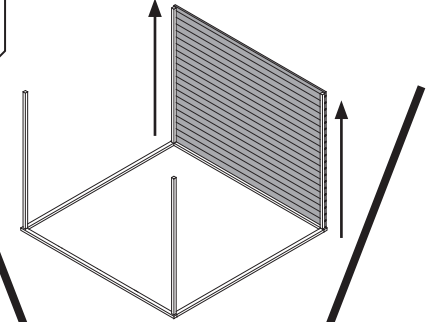
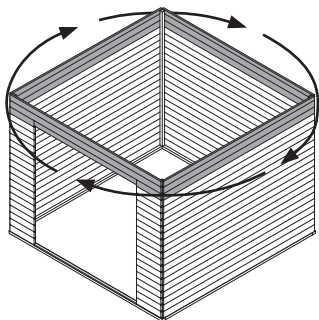
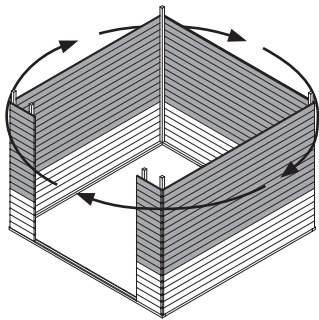
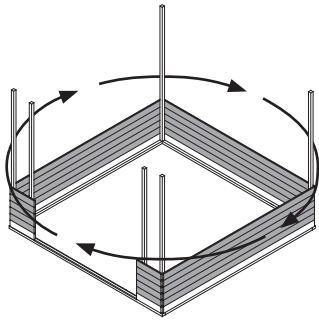
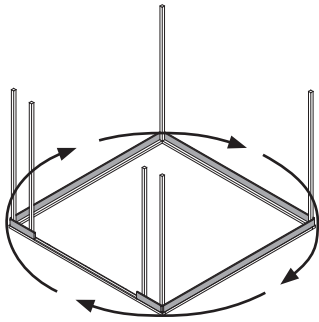
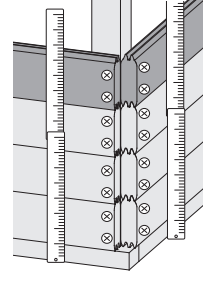
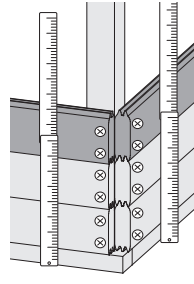
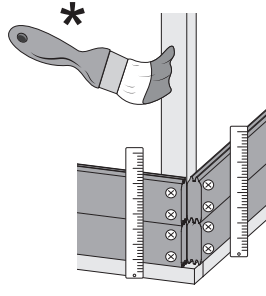
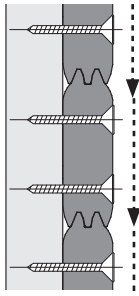

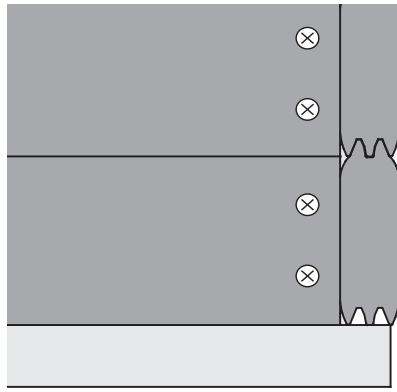
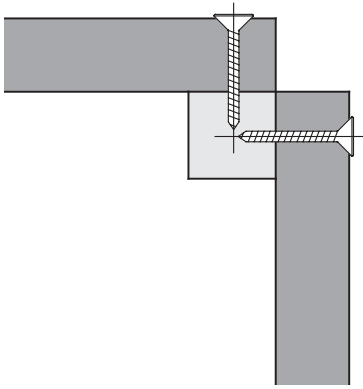

40x

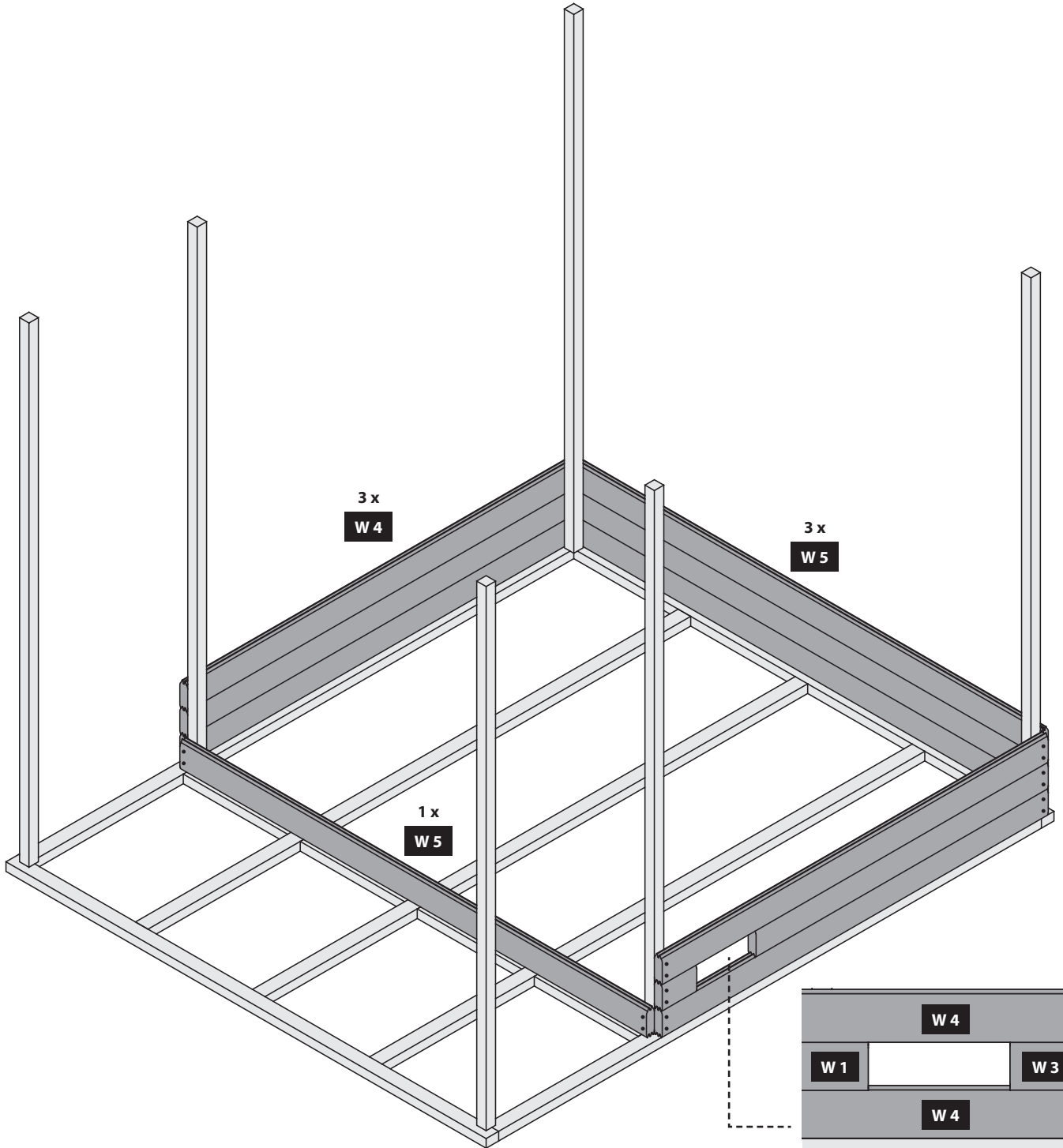
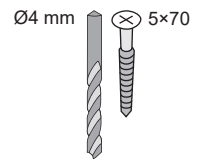

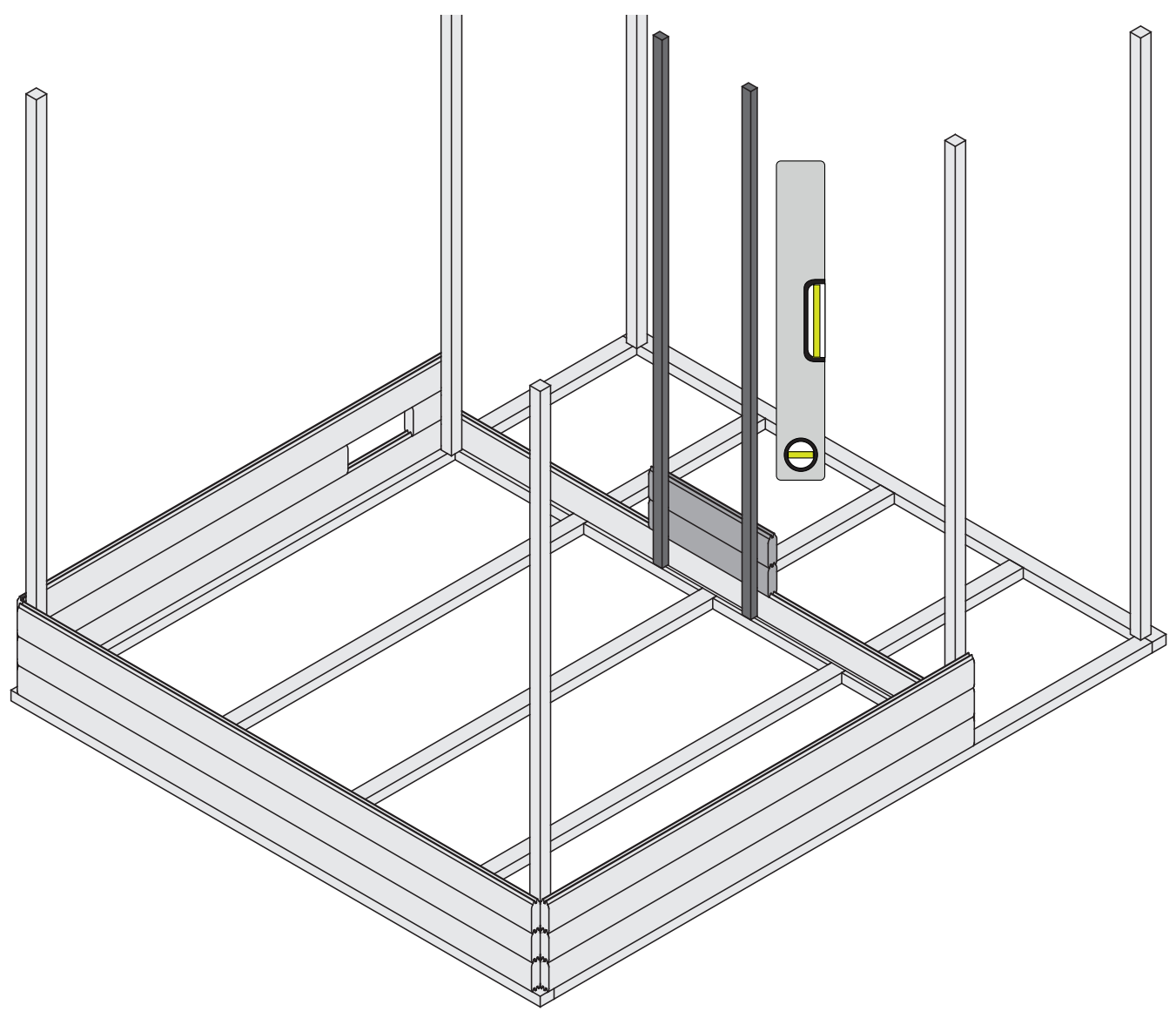
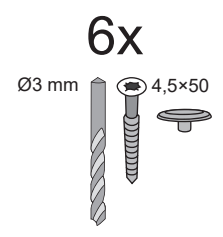
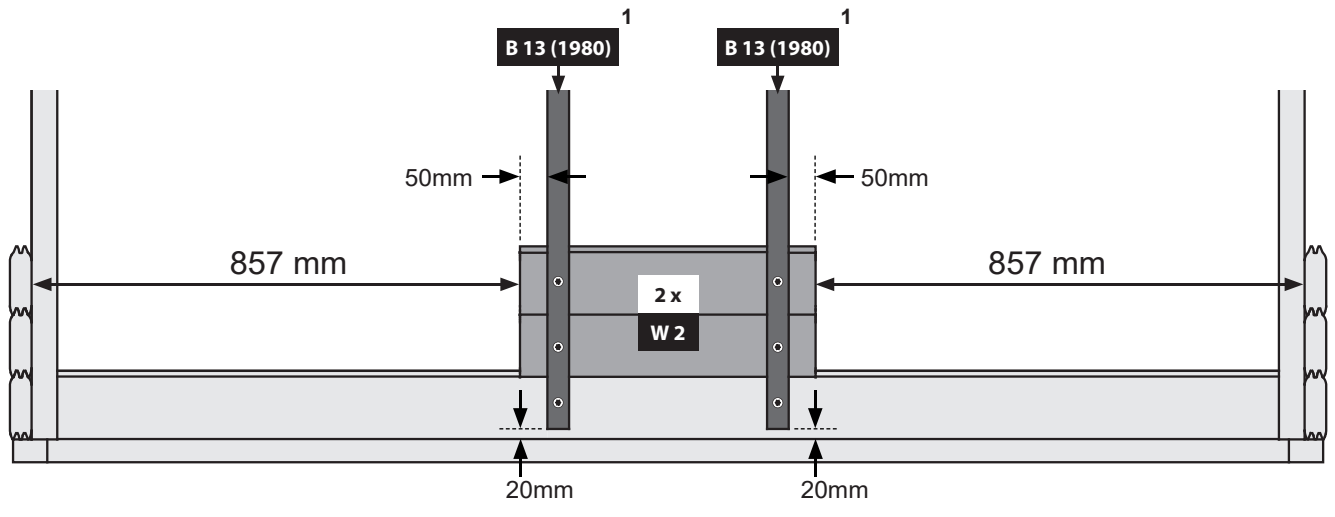

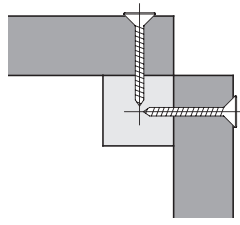
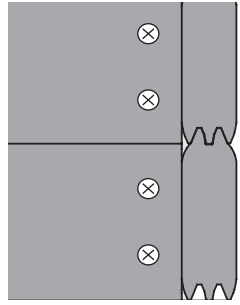
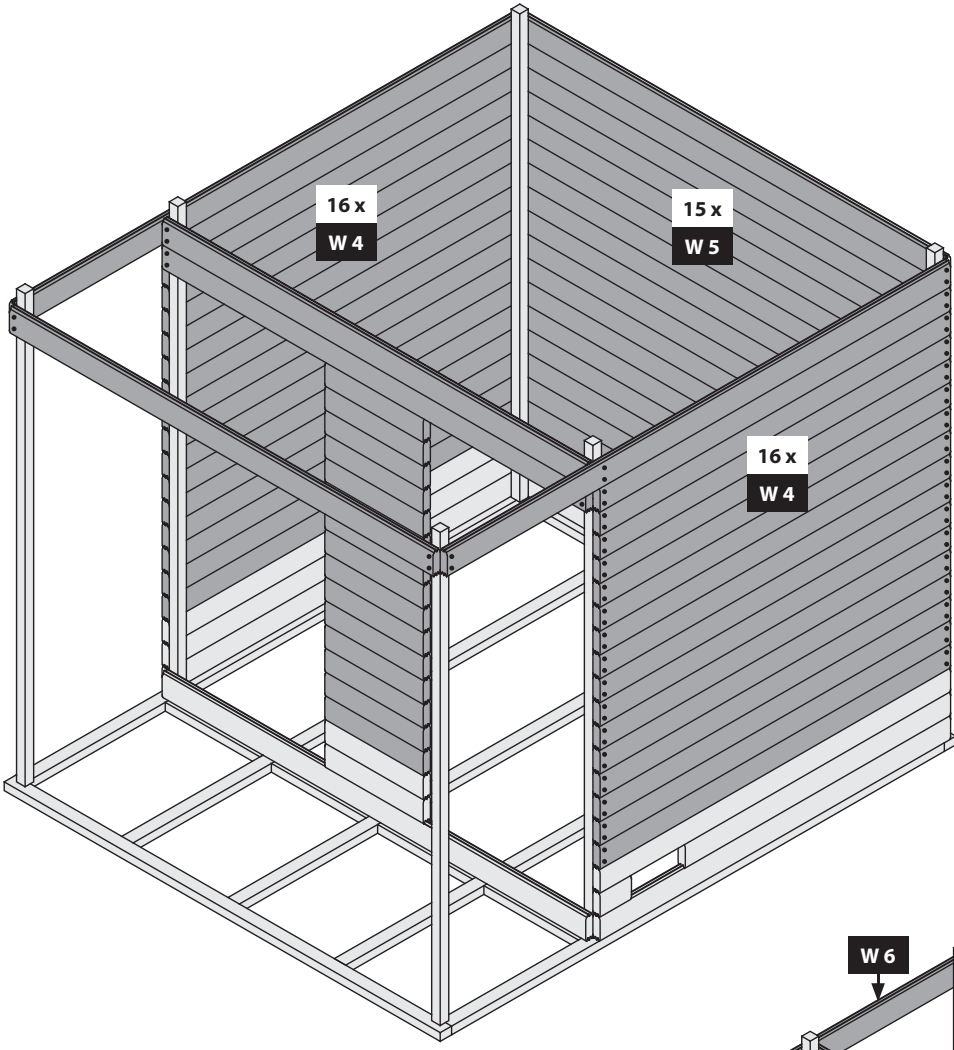

216x

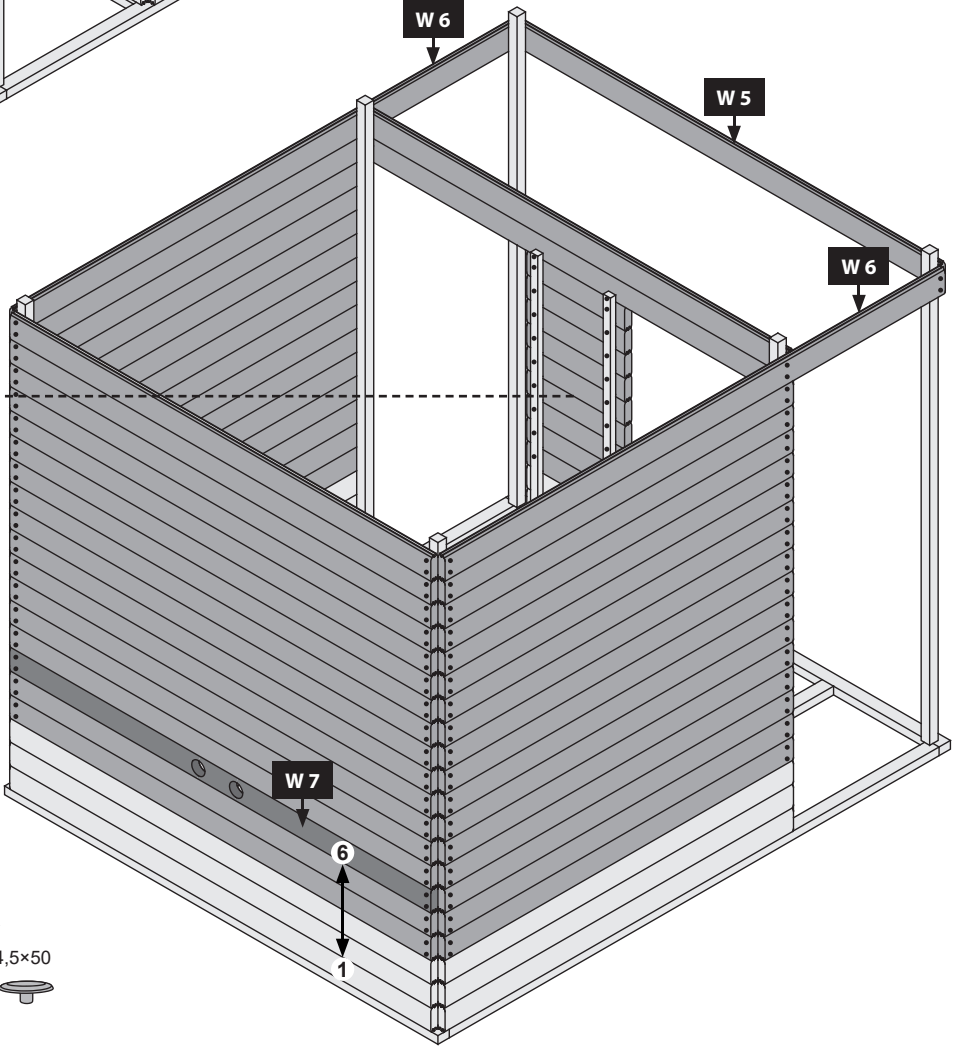
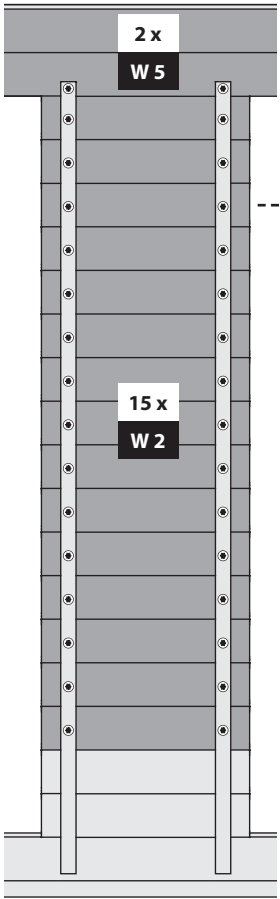
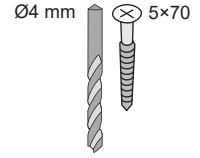

32x

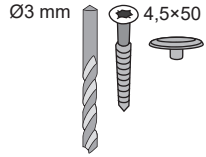

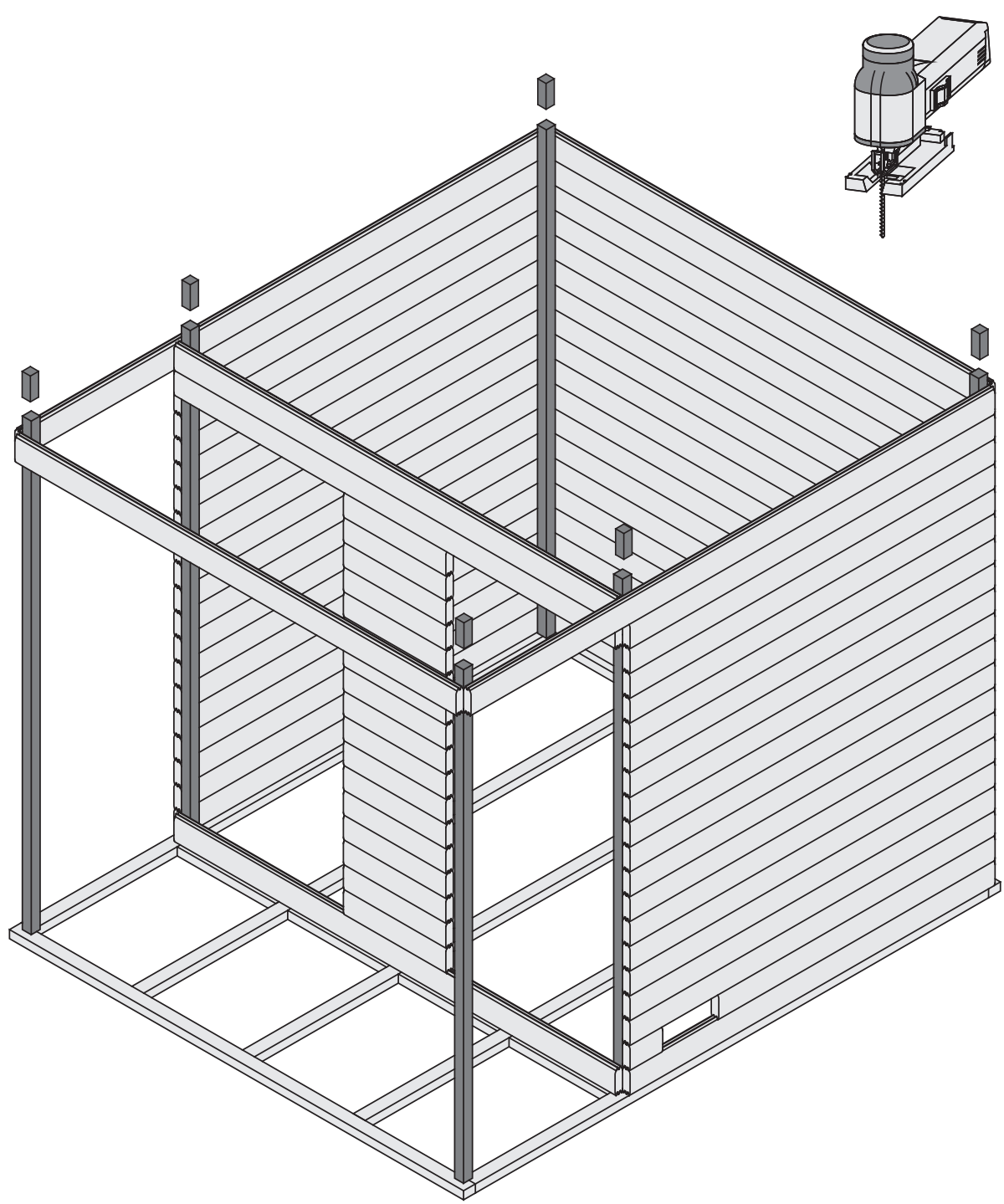
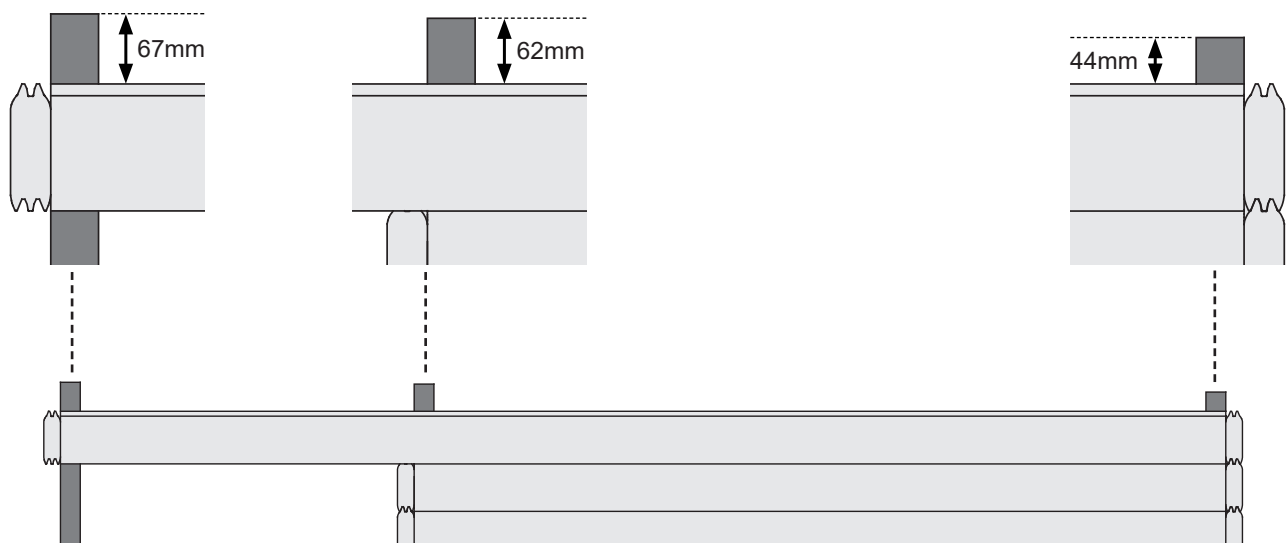

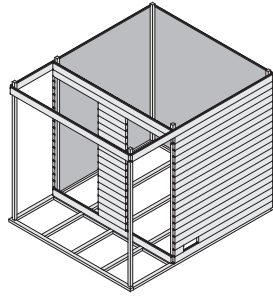

A=A
B=B

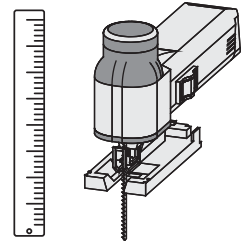
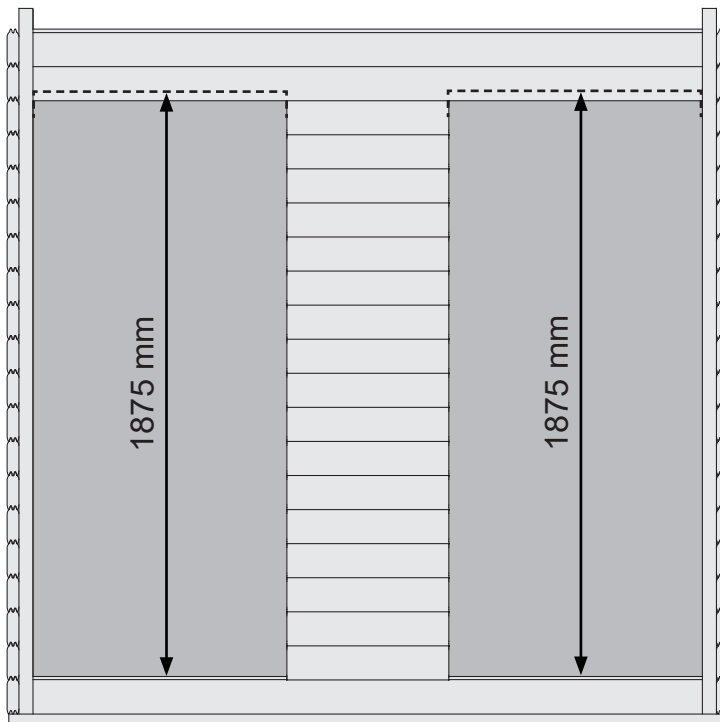
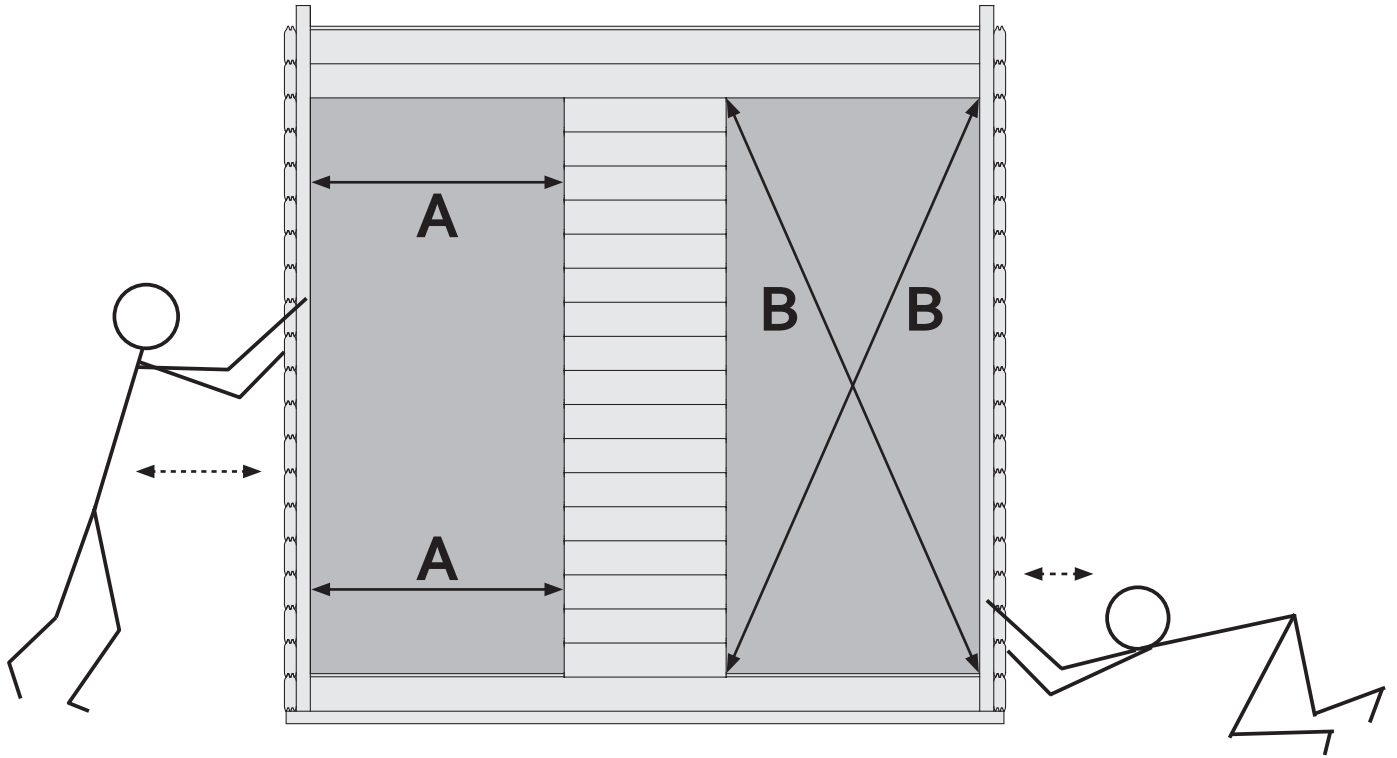

12x
Ø4 mm 5x70

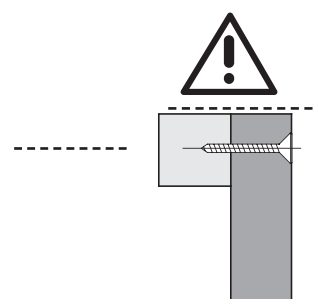
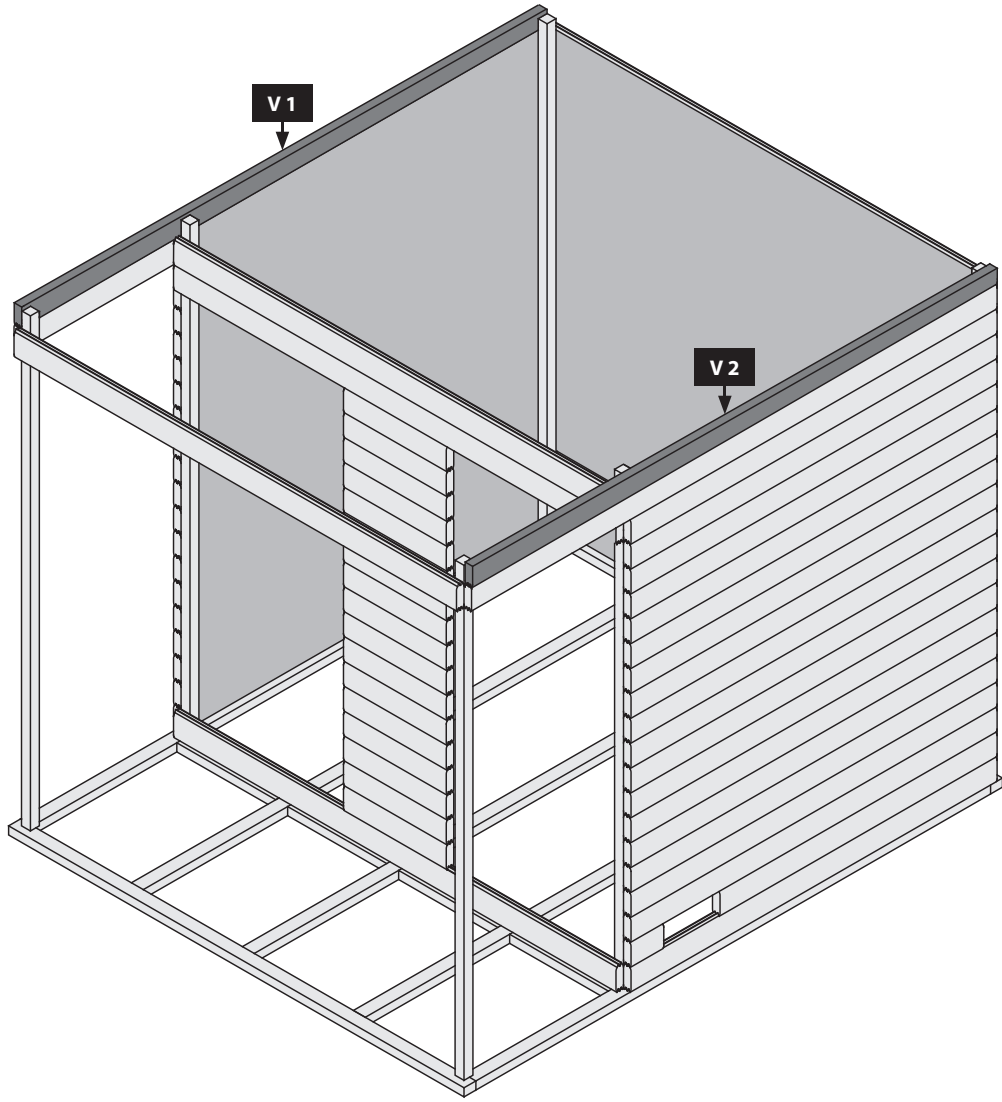
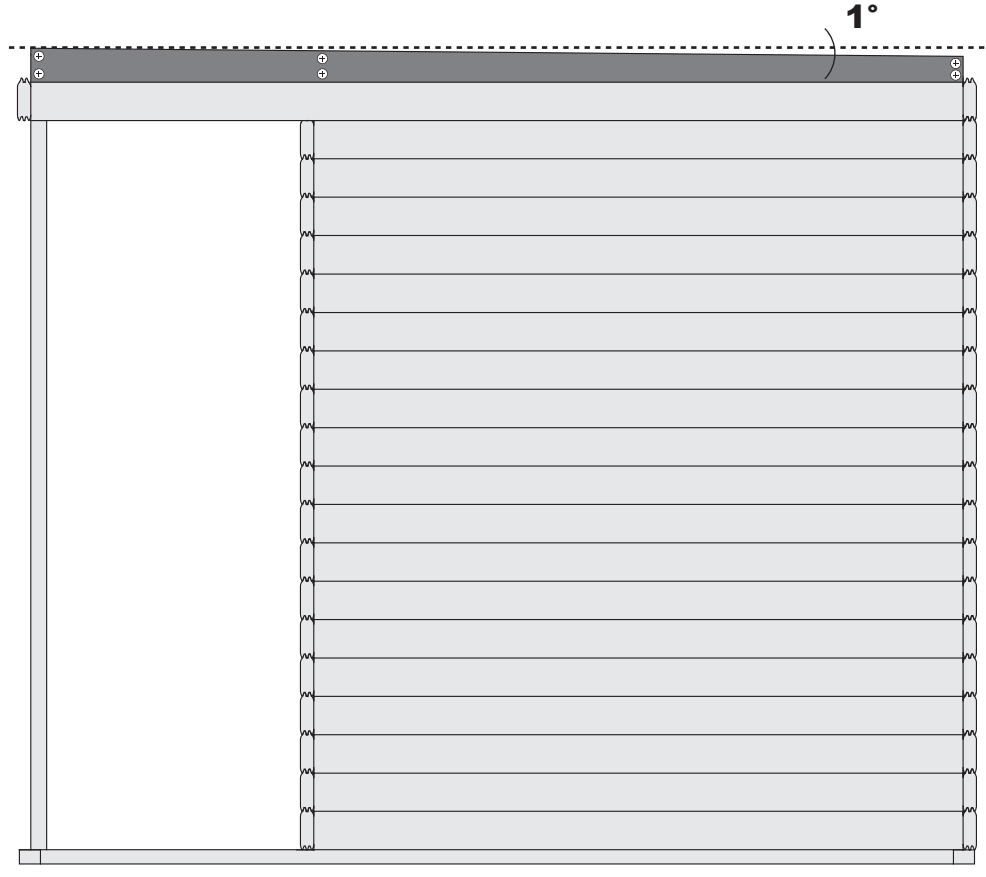

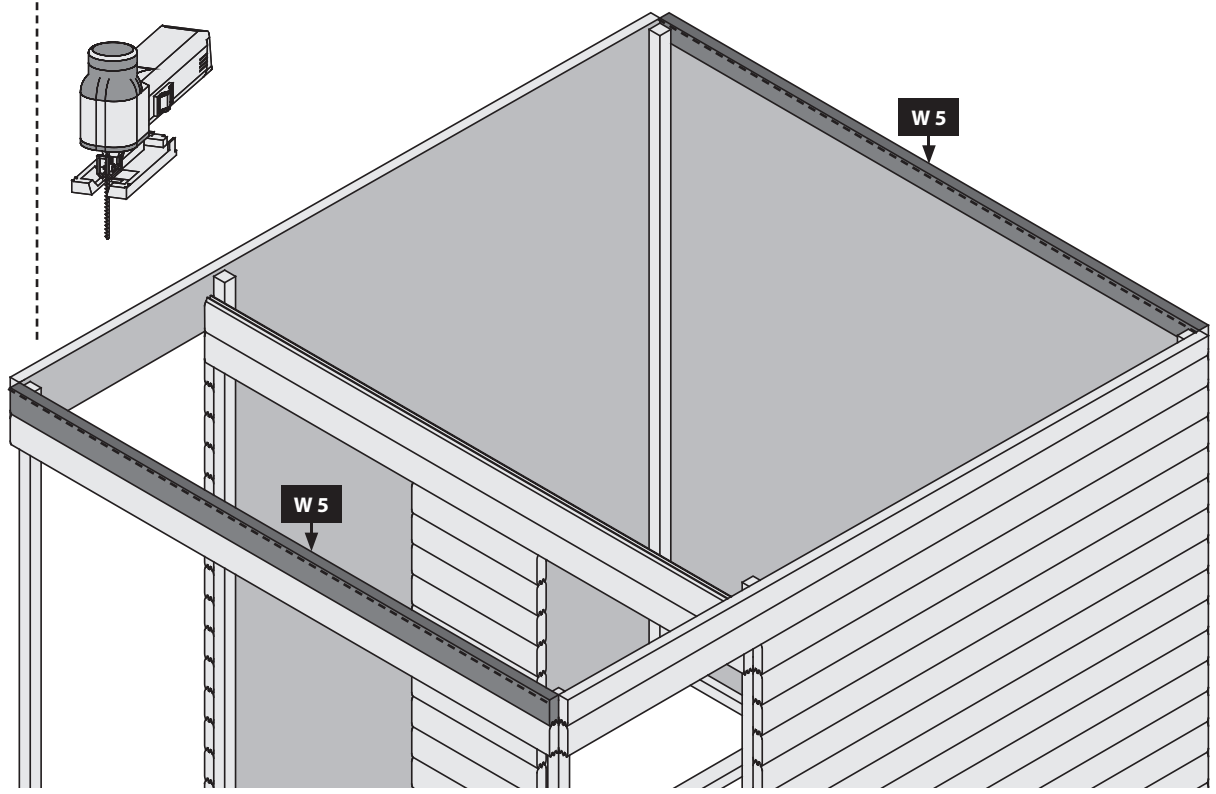
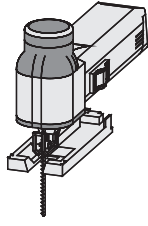
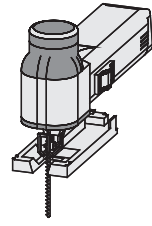
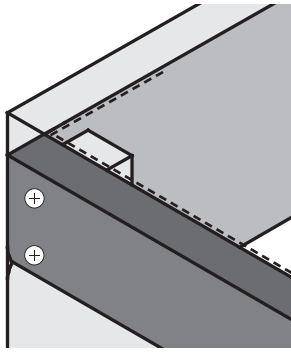
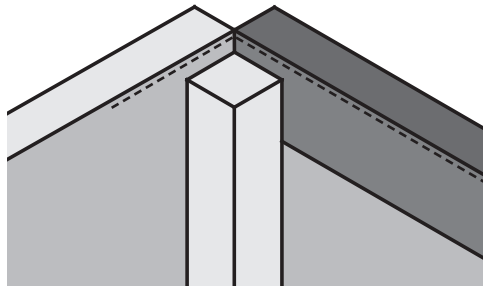

8x

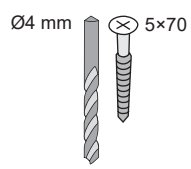

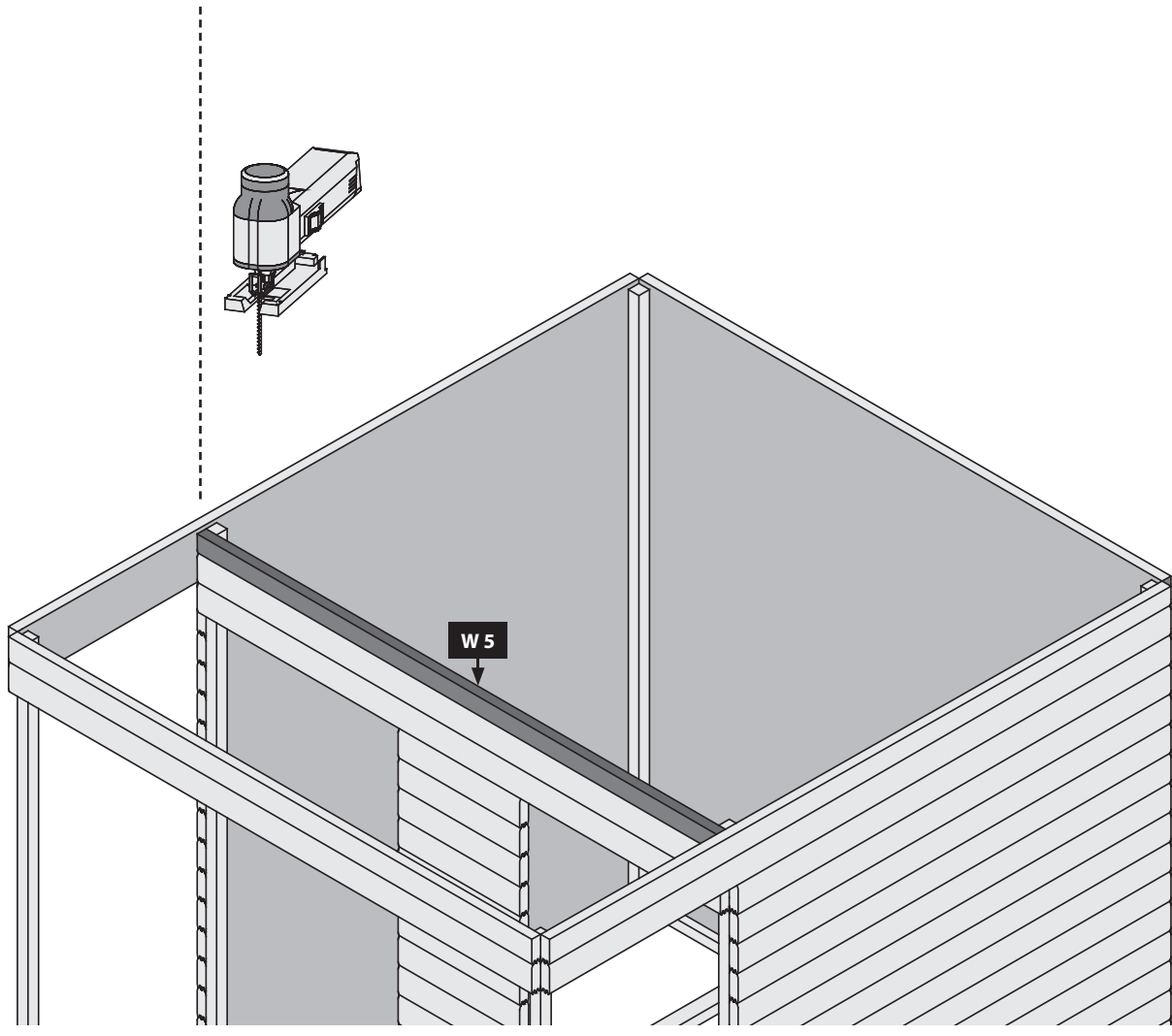
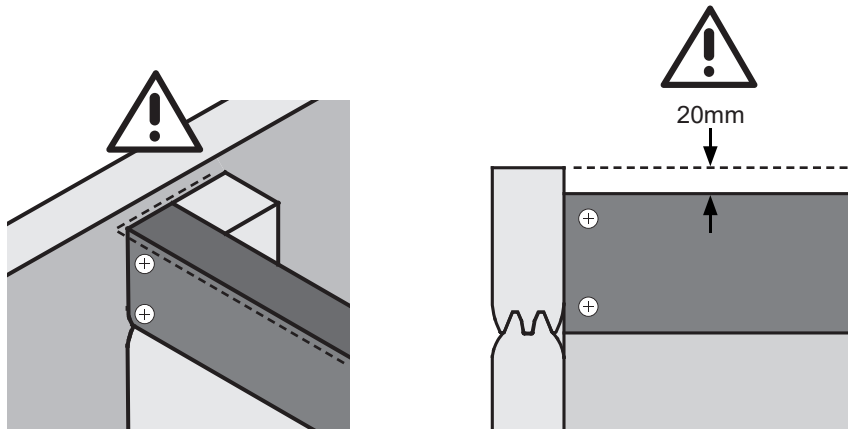

4x

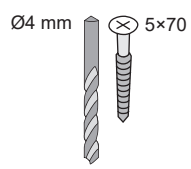

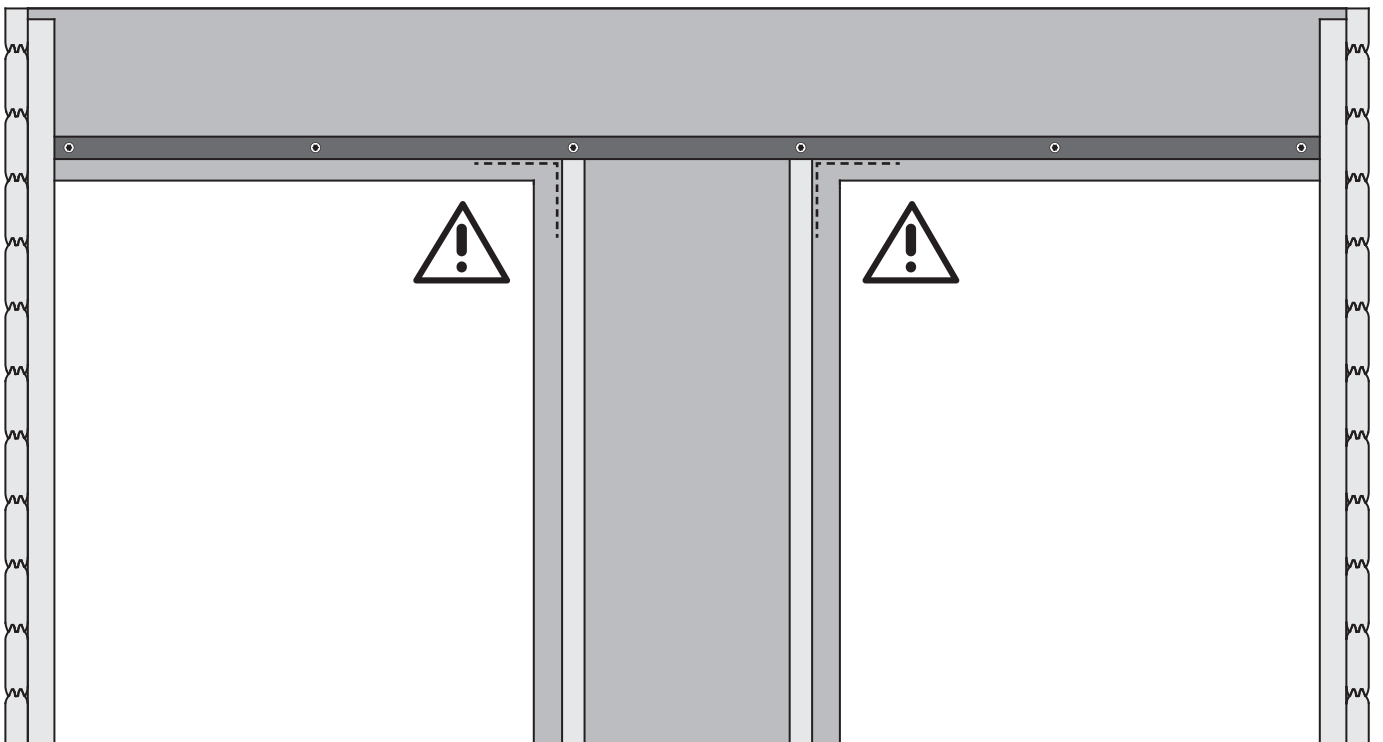
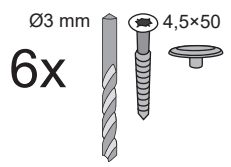
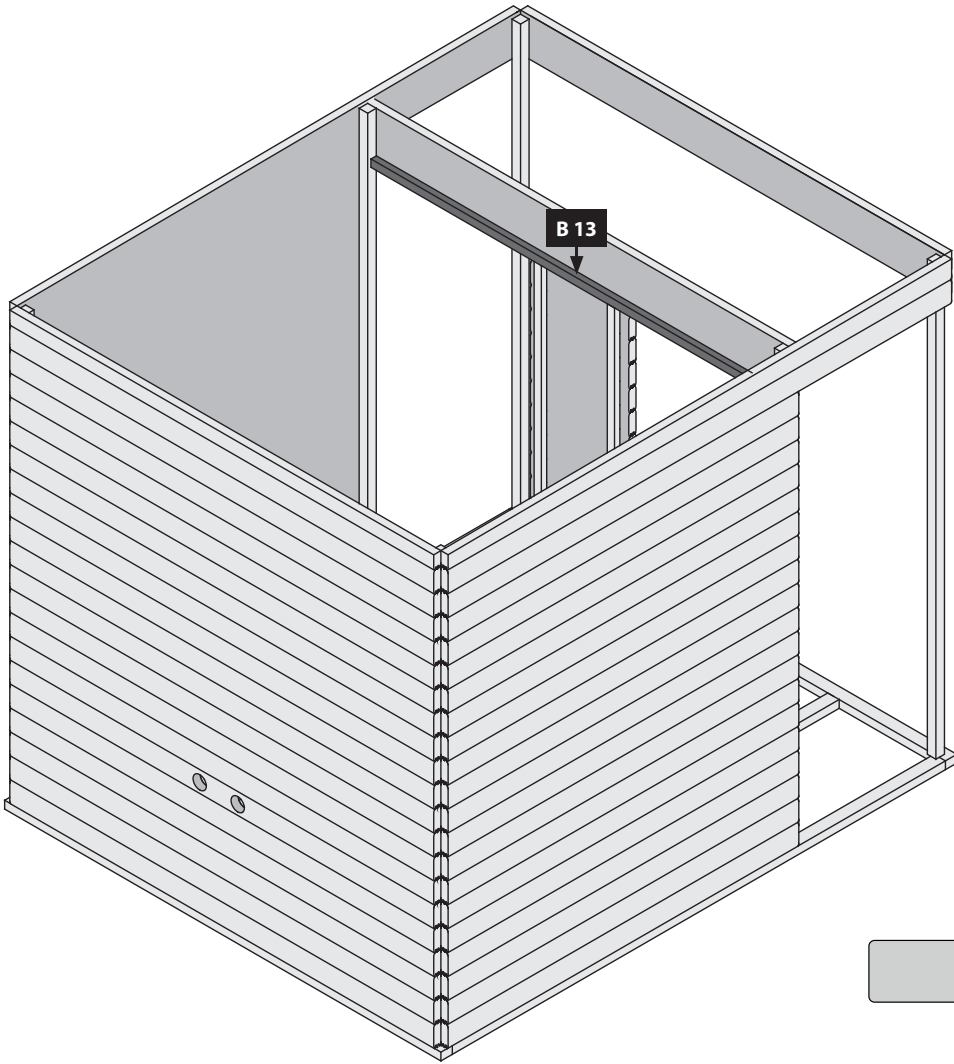

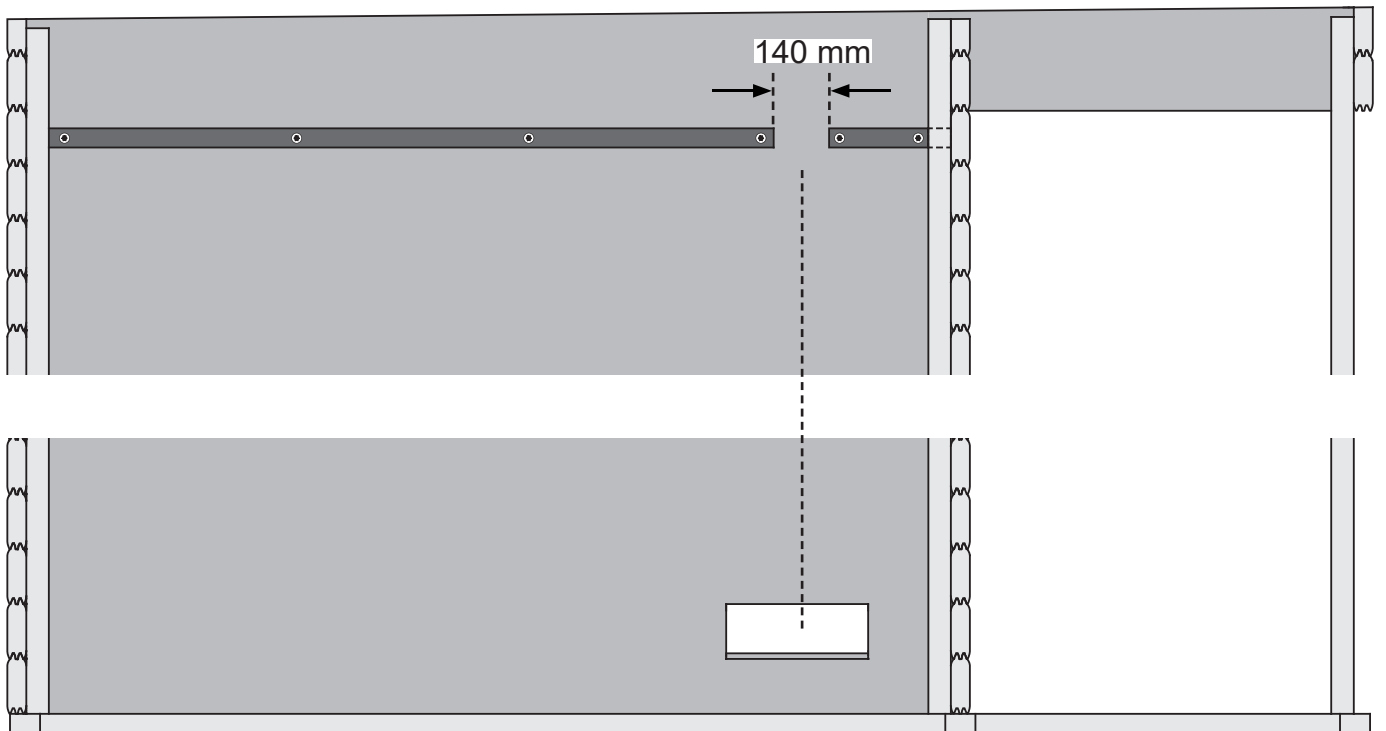
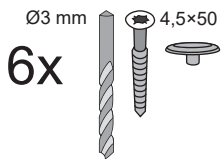
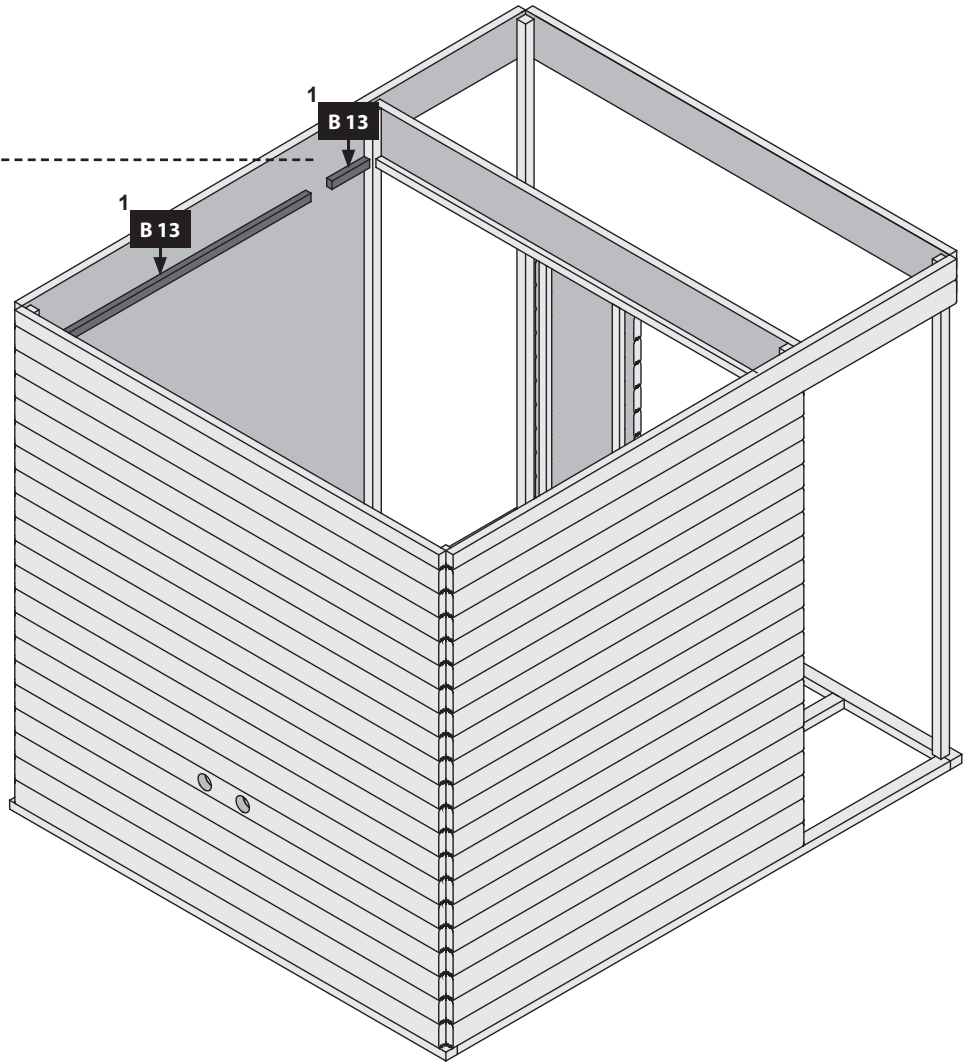
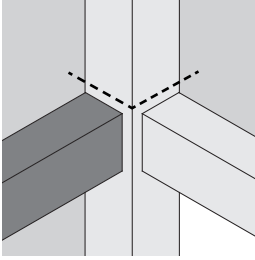

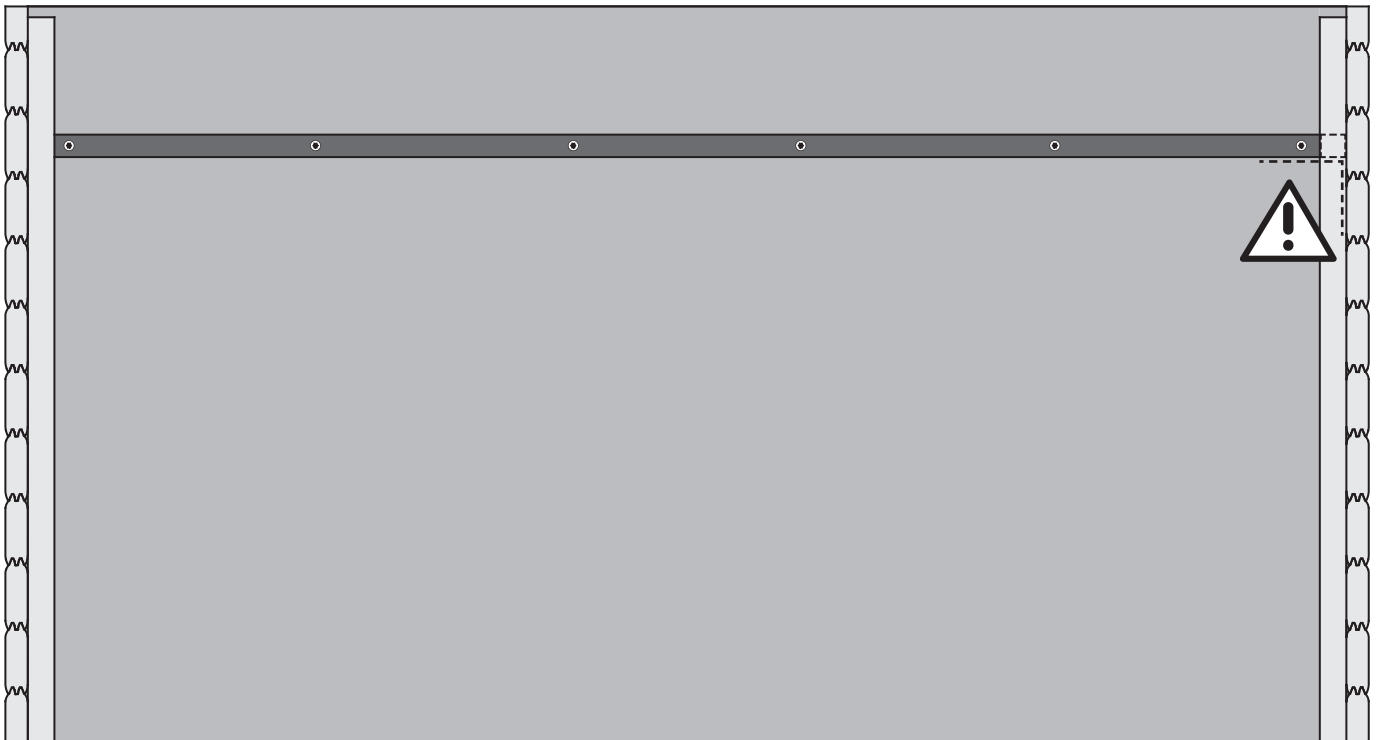
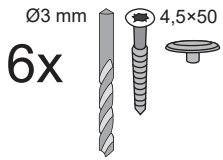
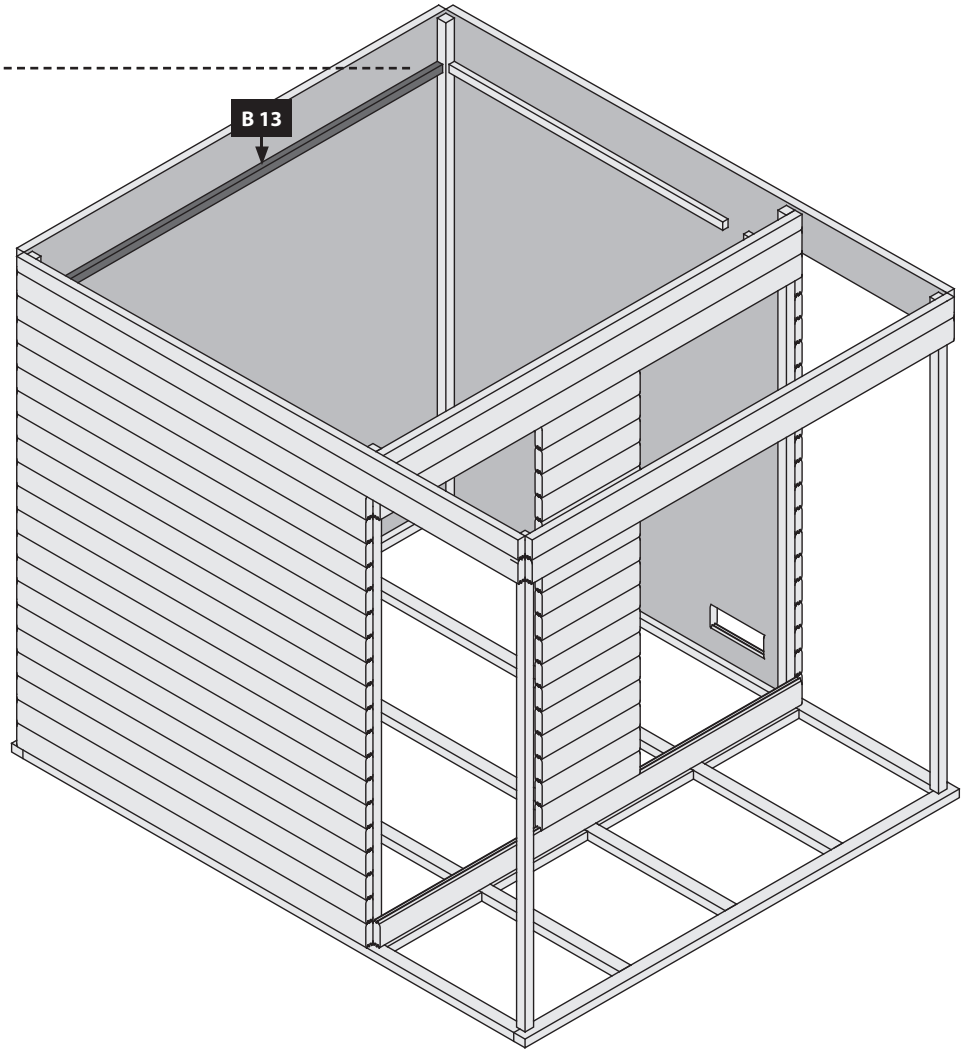
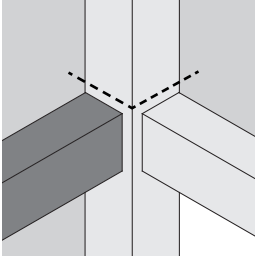

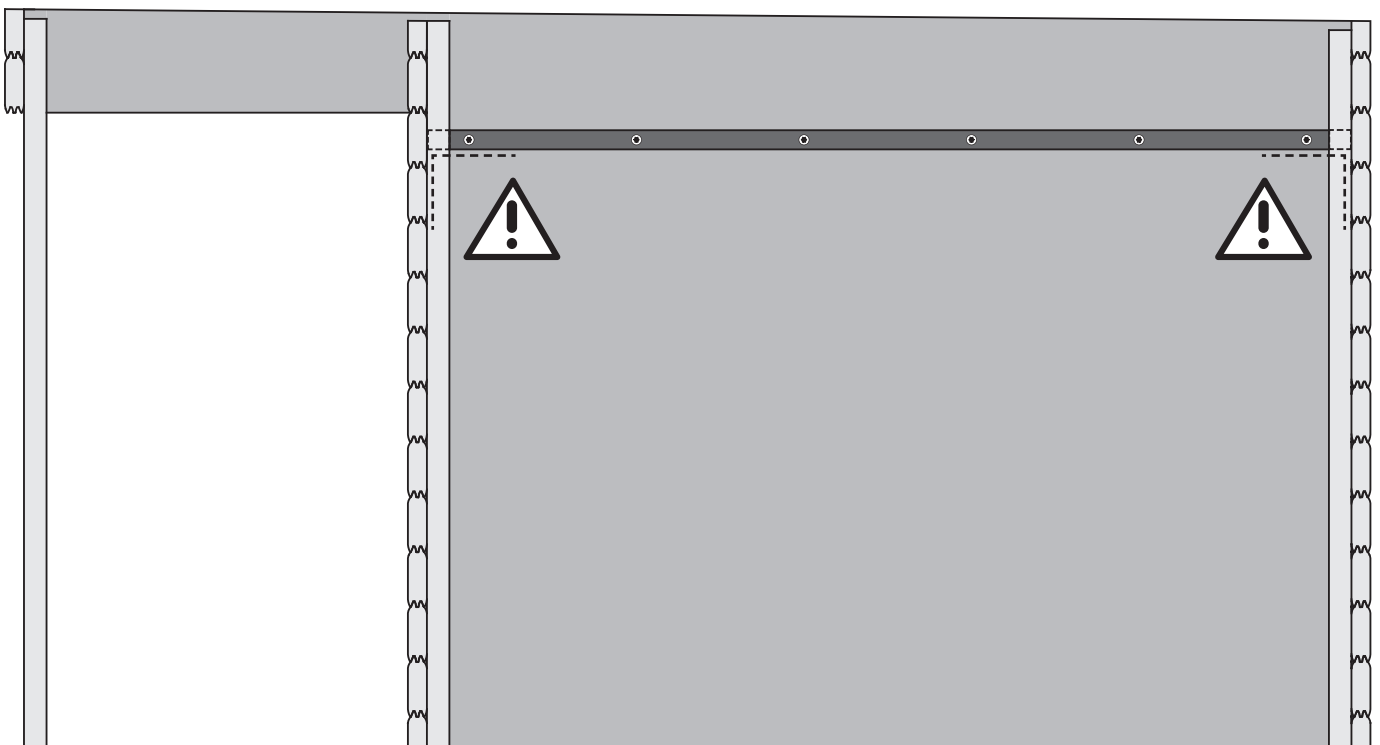
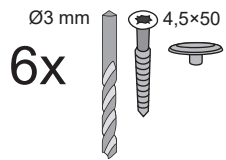
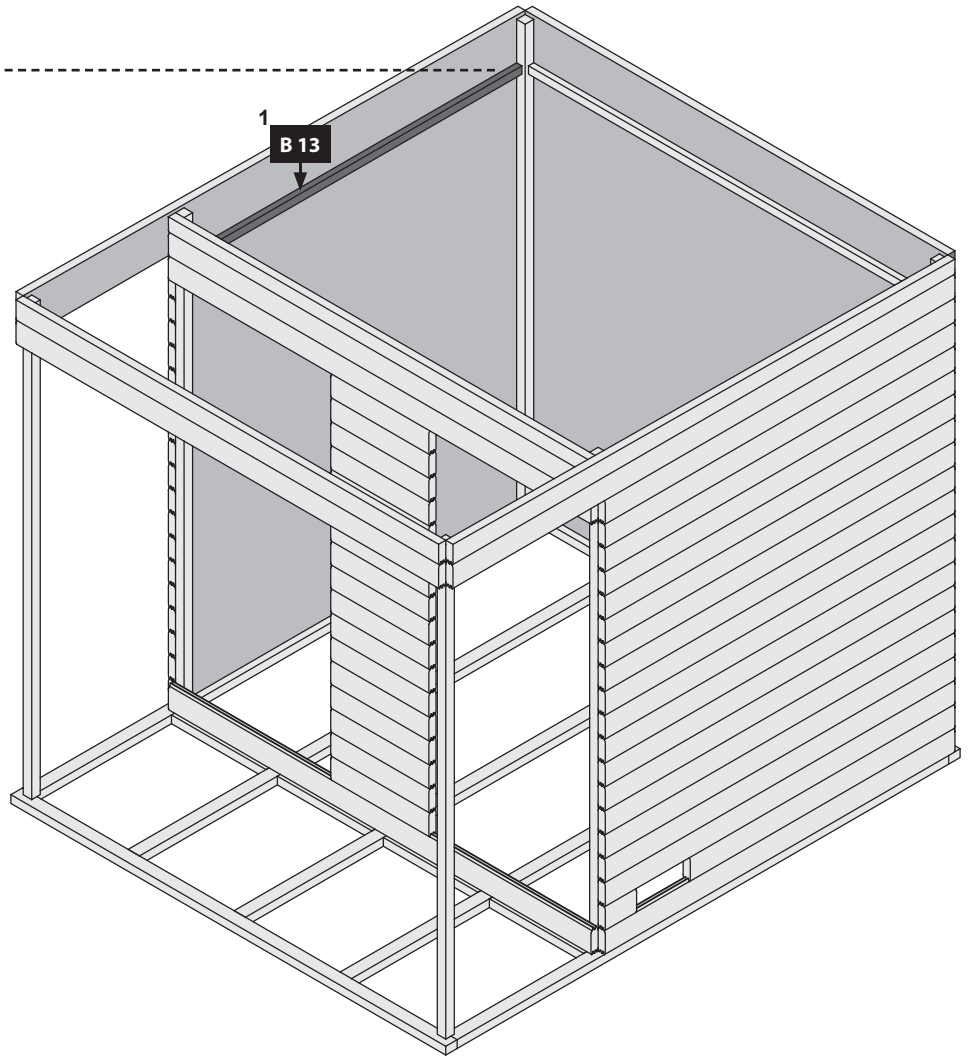
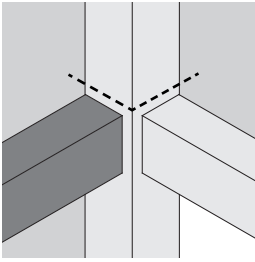

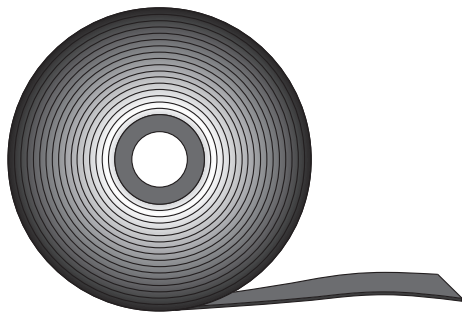

16

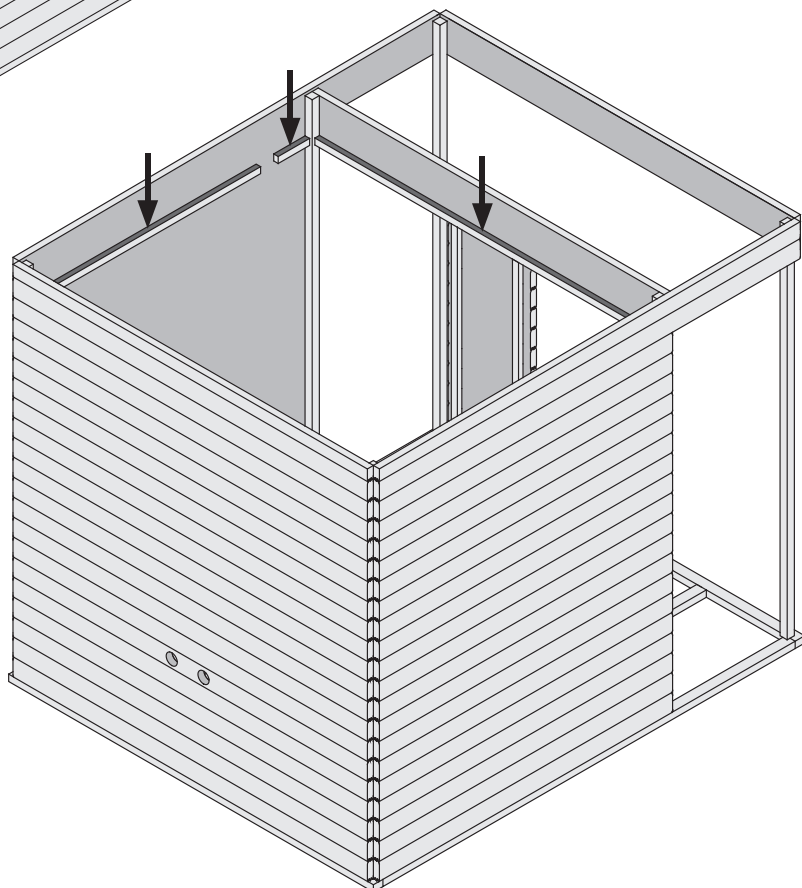
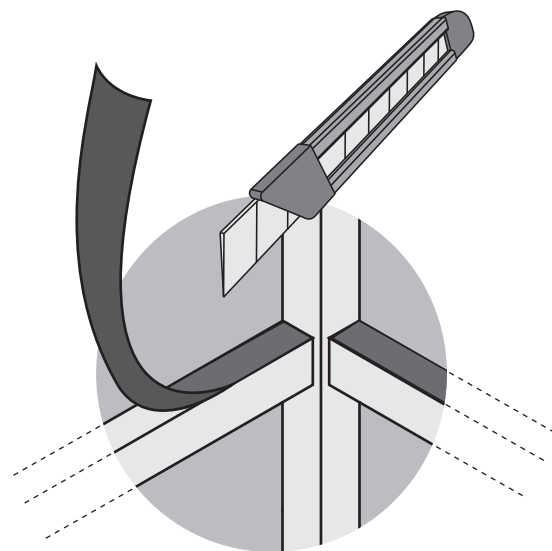
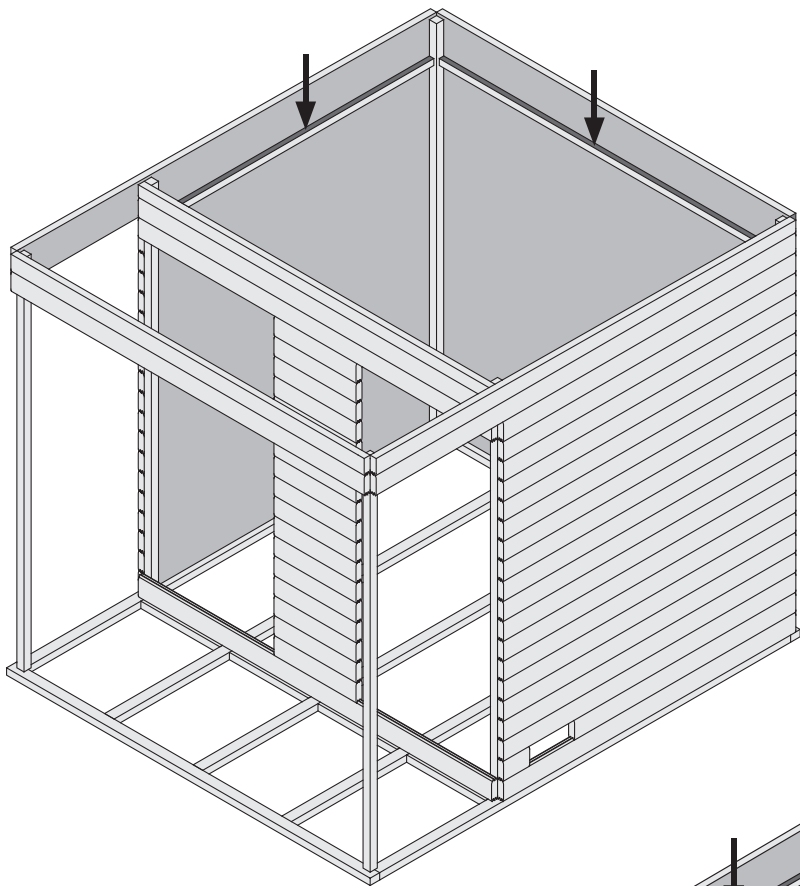

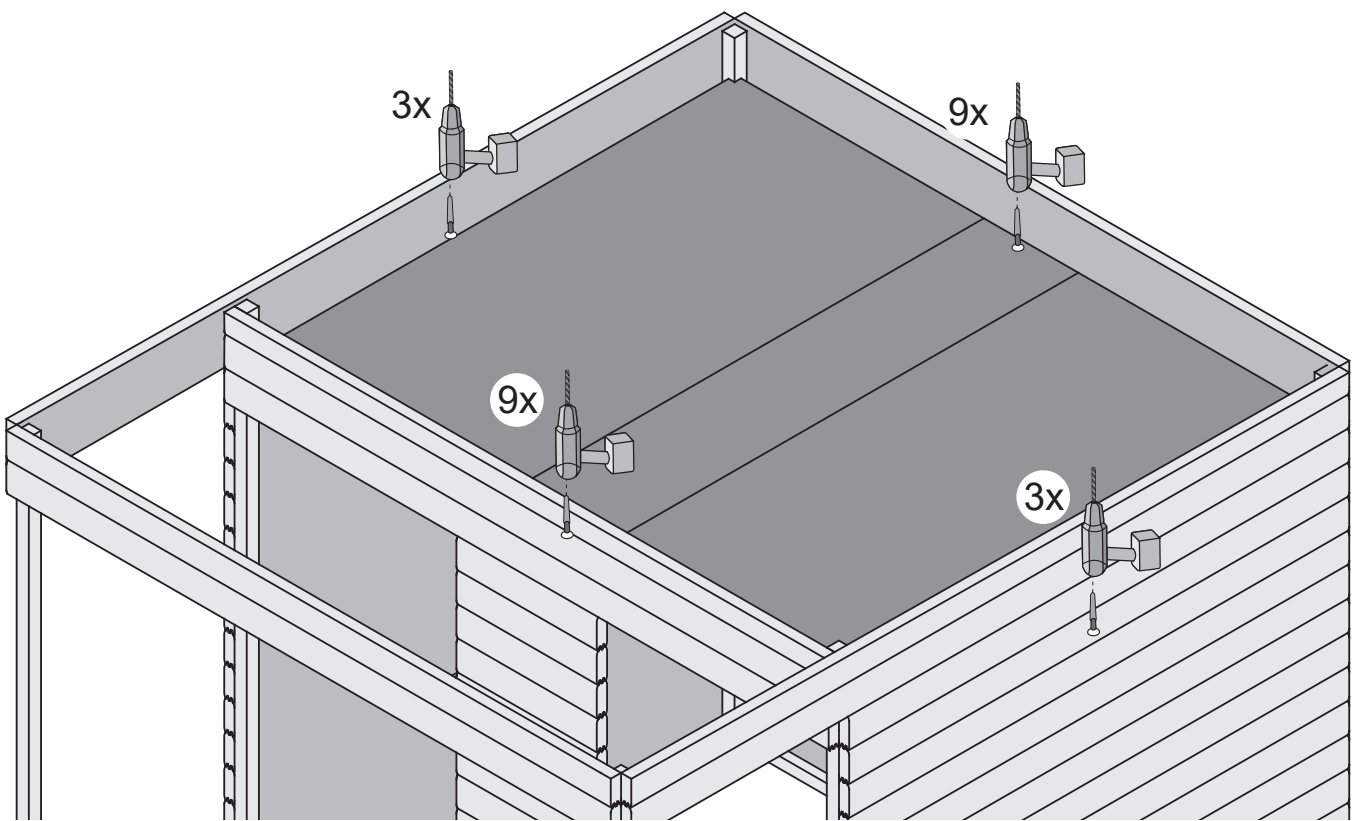
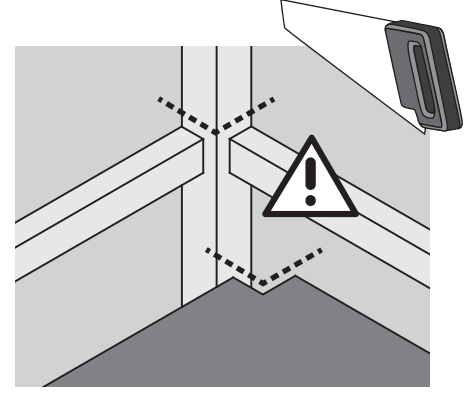
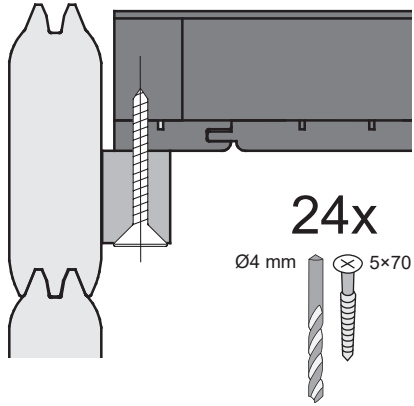
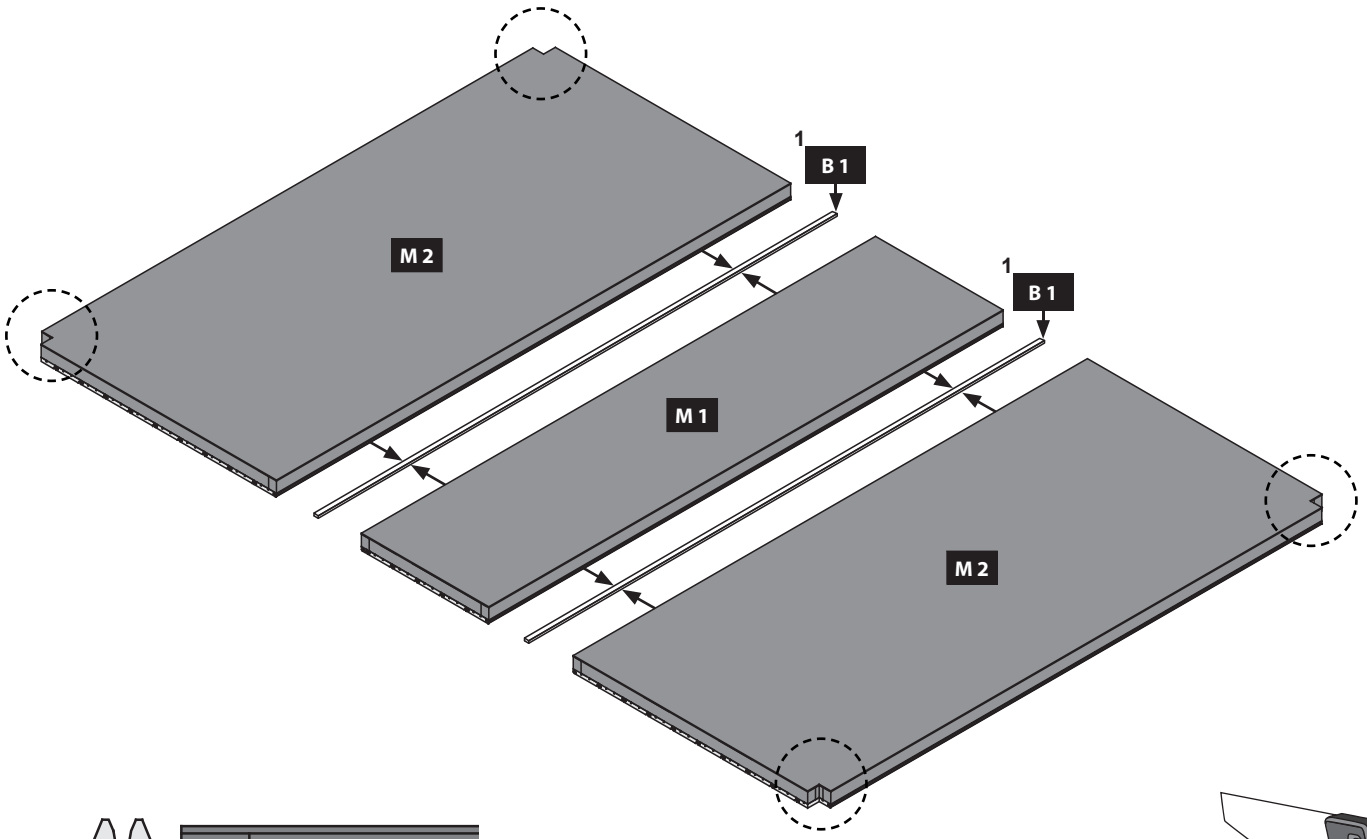

48x

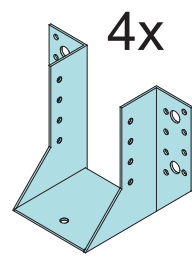
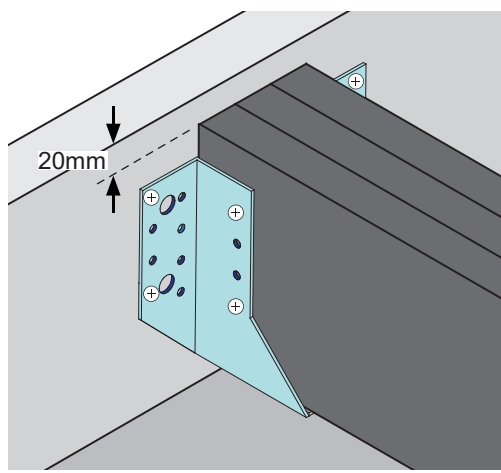
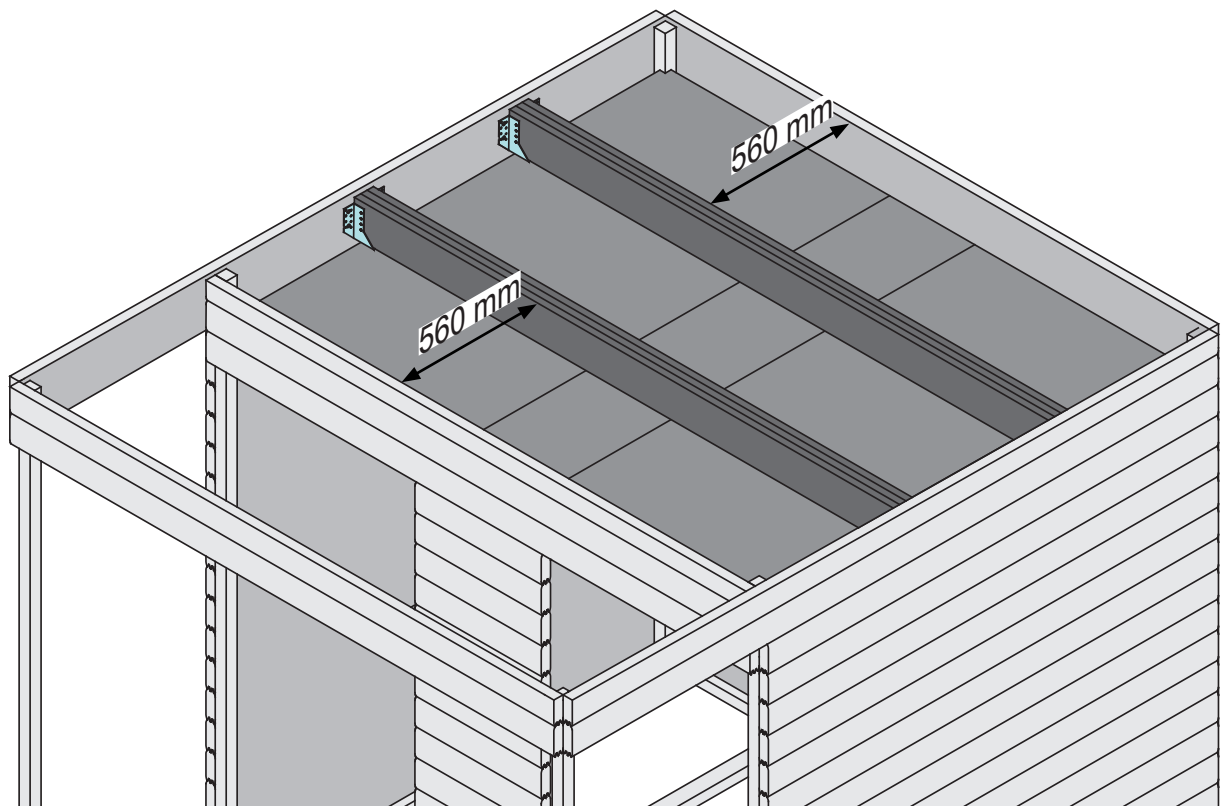
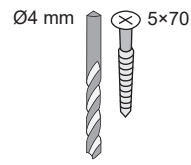

4x

32x

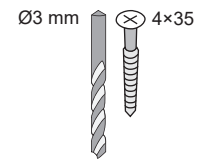

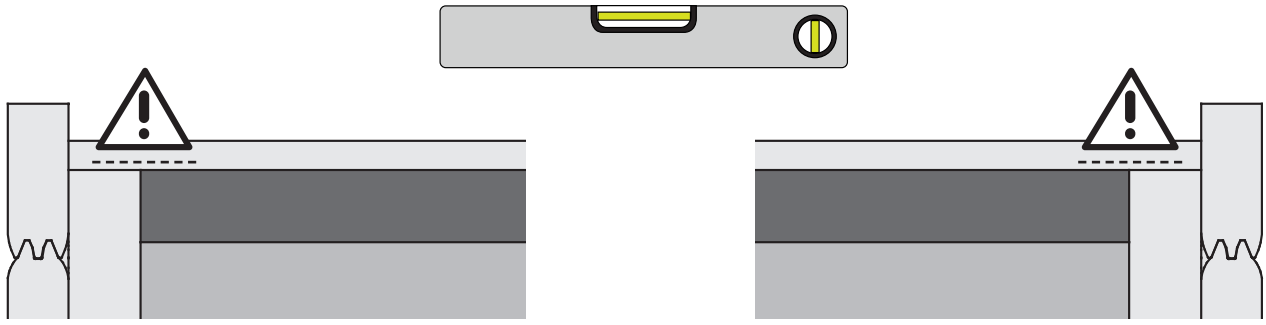

8x
Ø4 mm 5x70

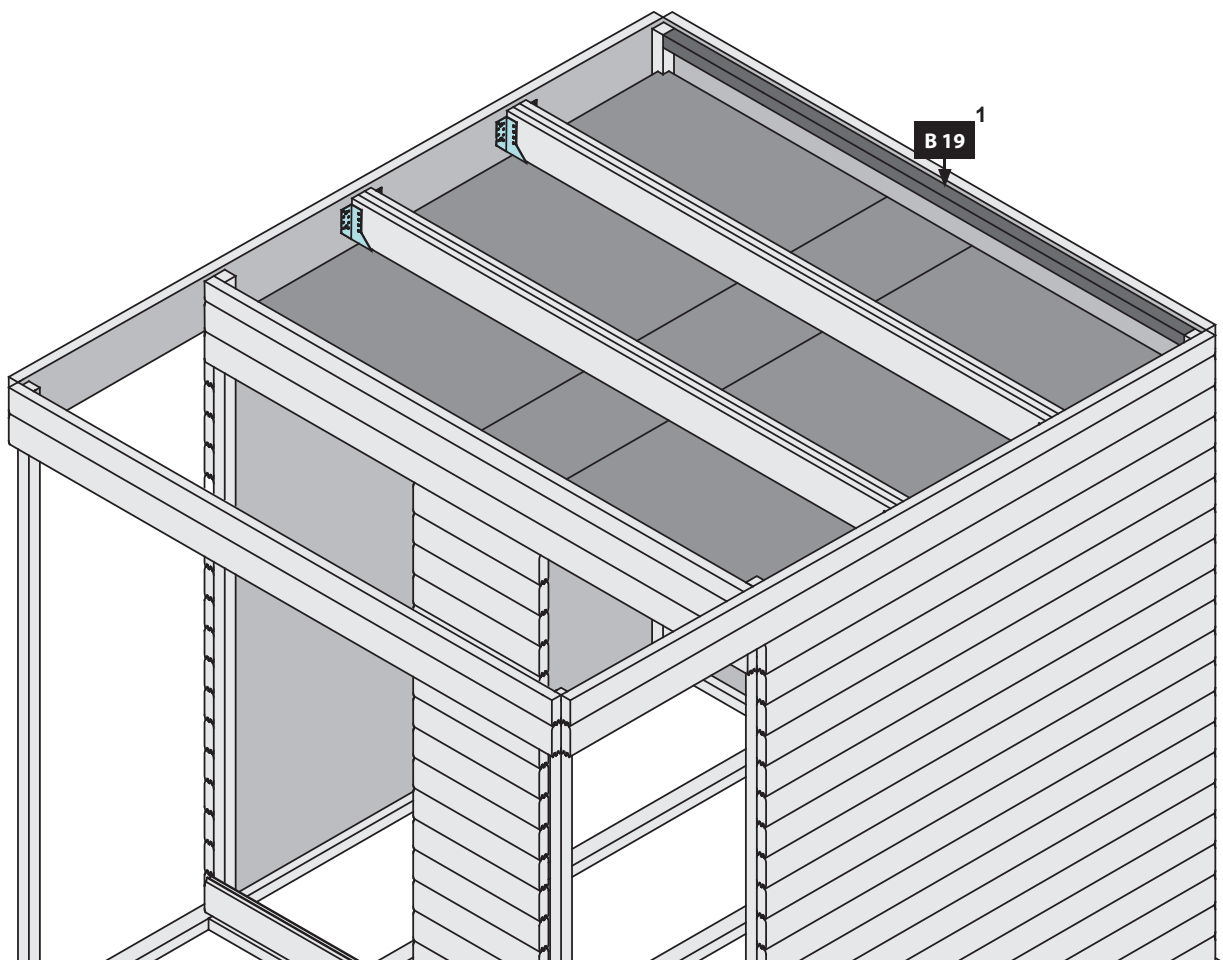
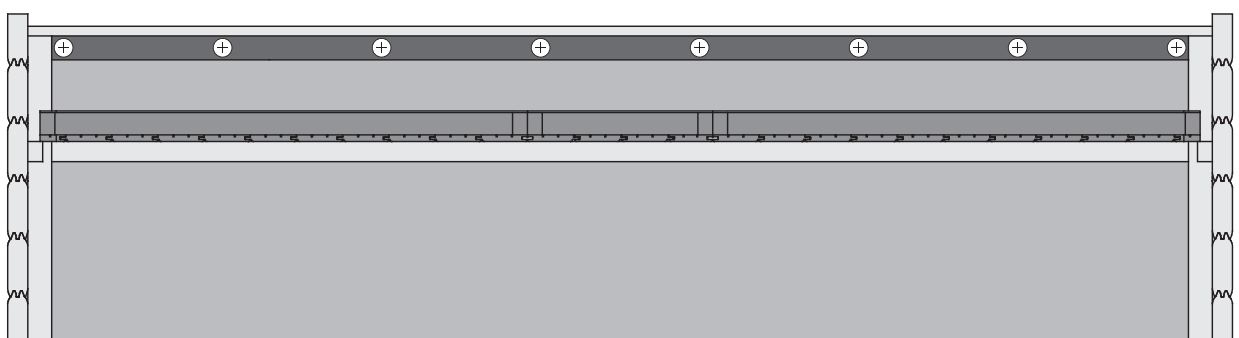

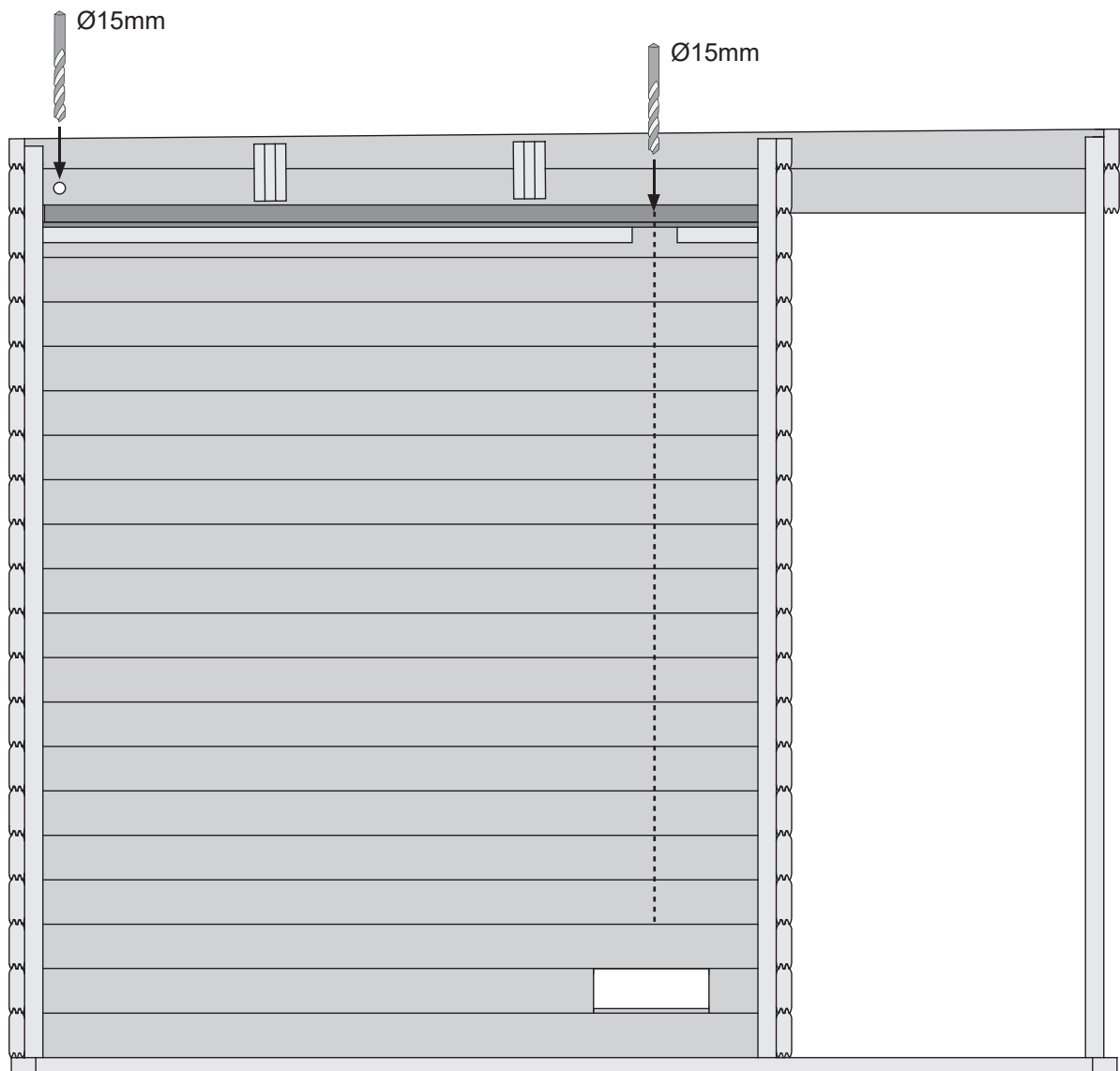
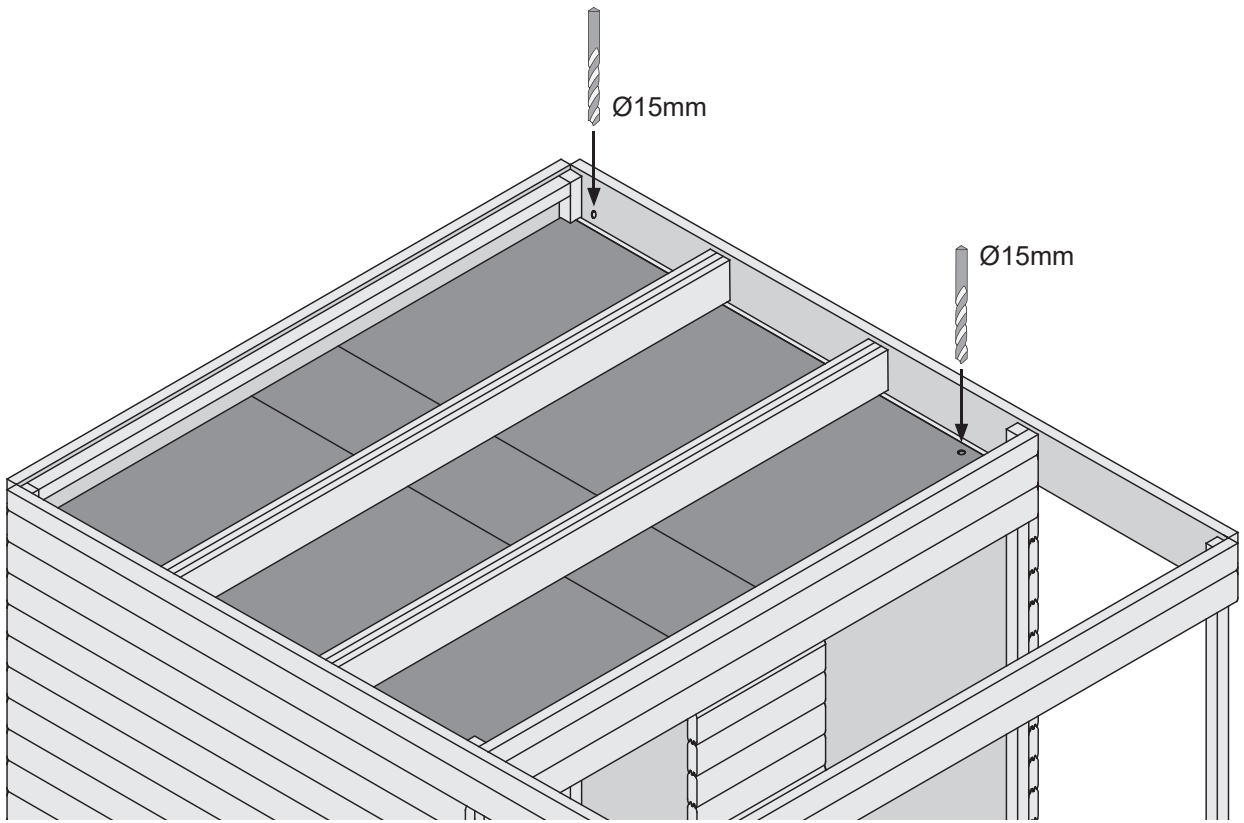

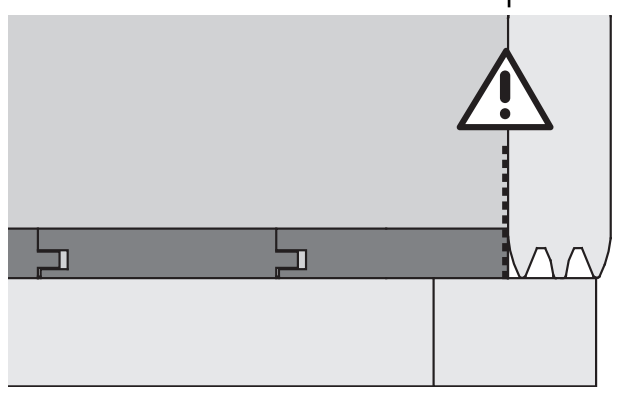
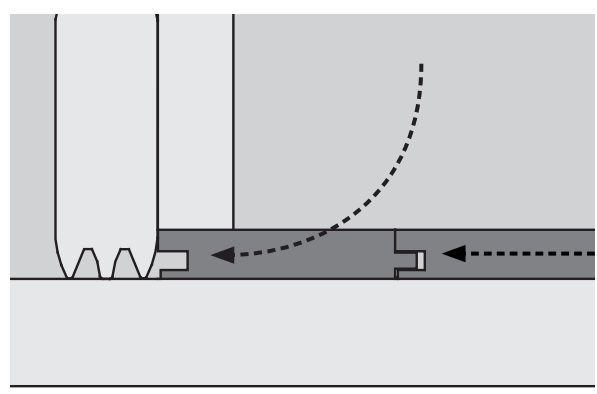
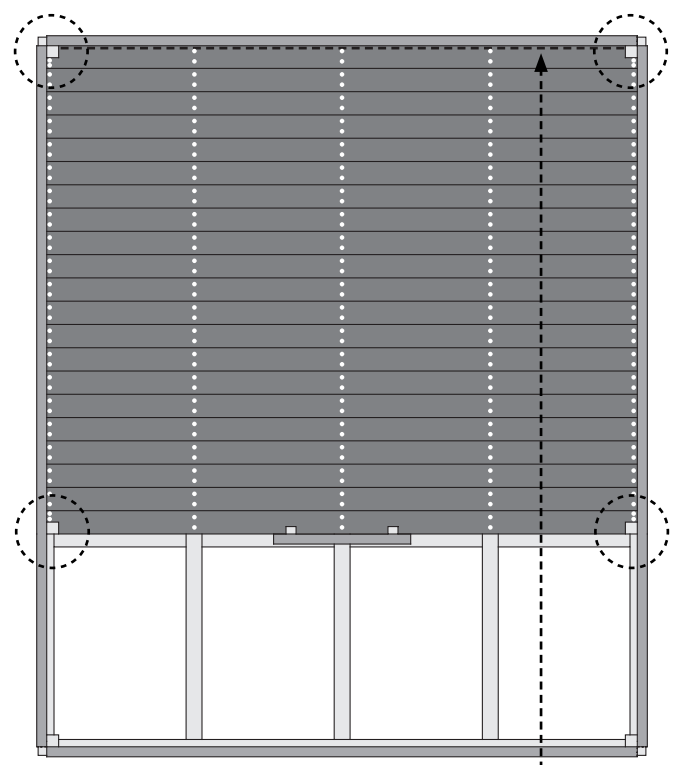
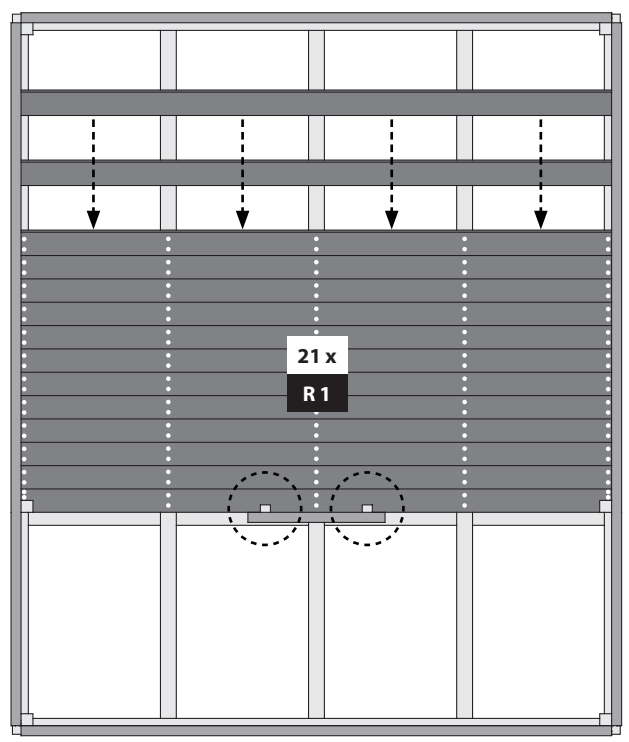
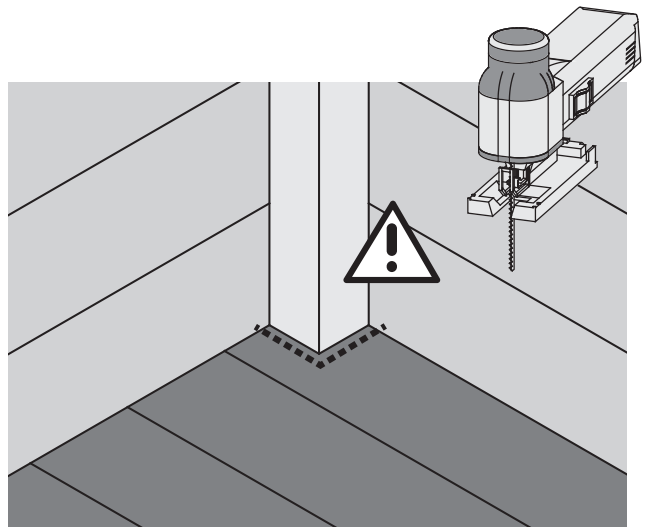
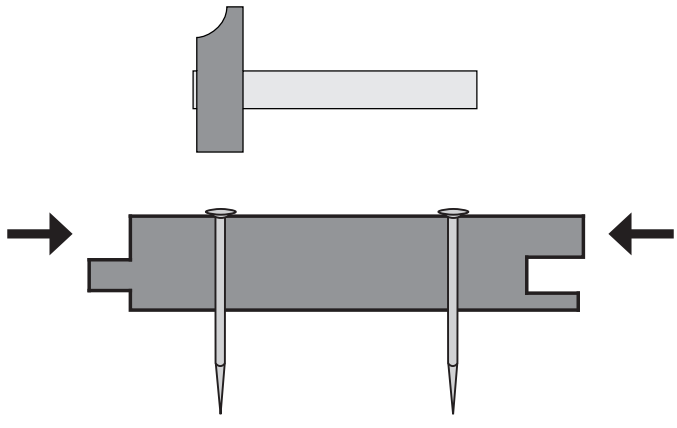

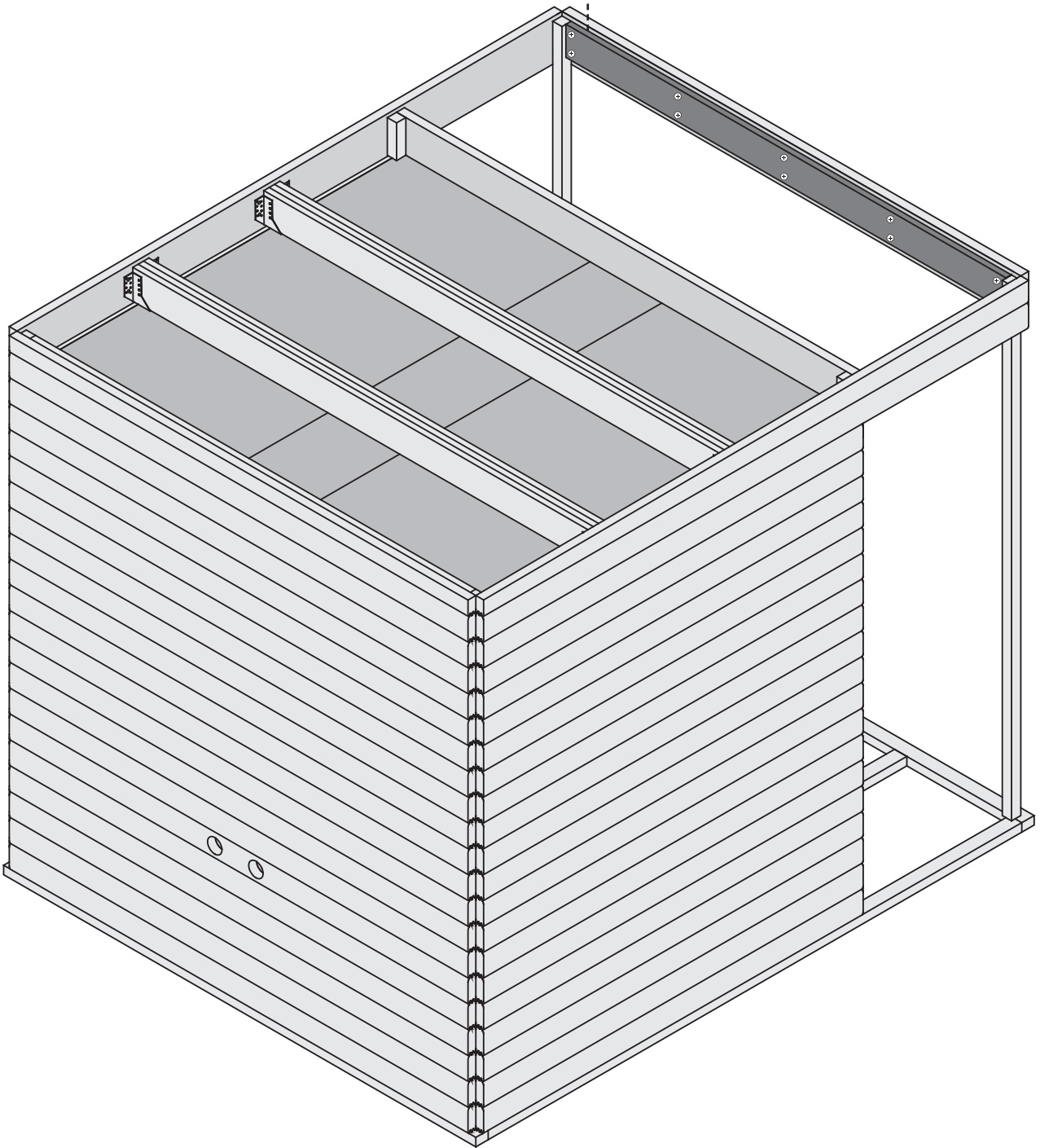
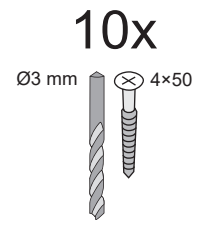
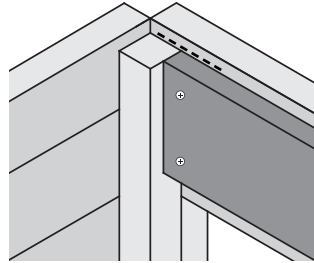
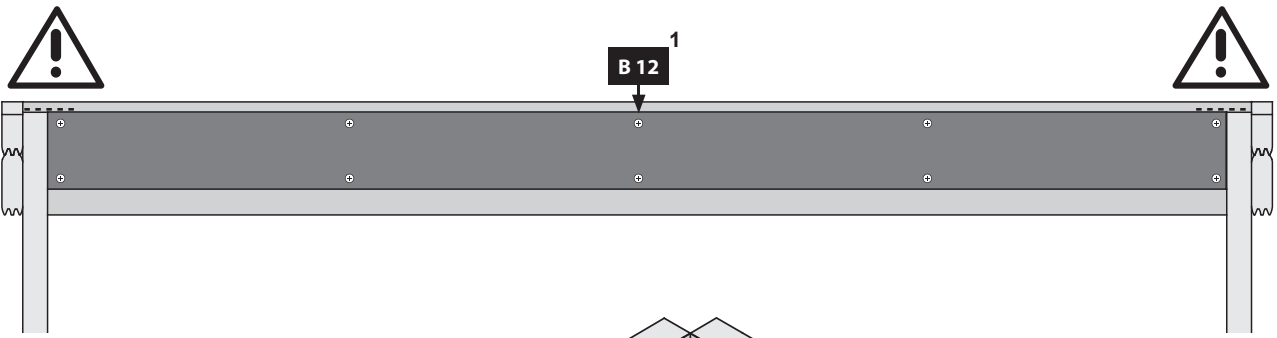

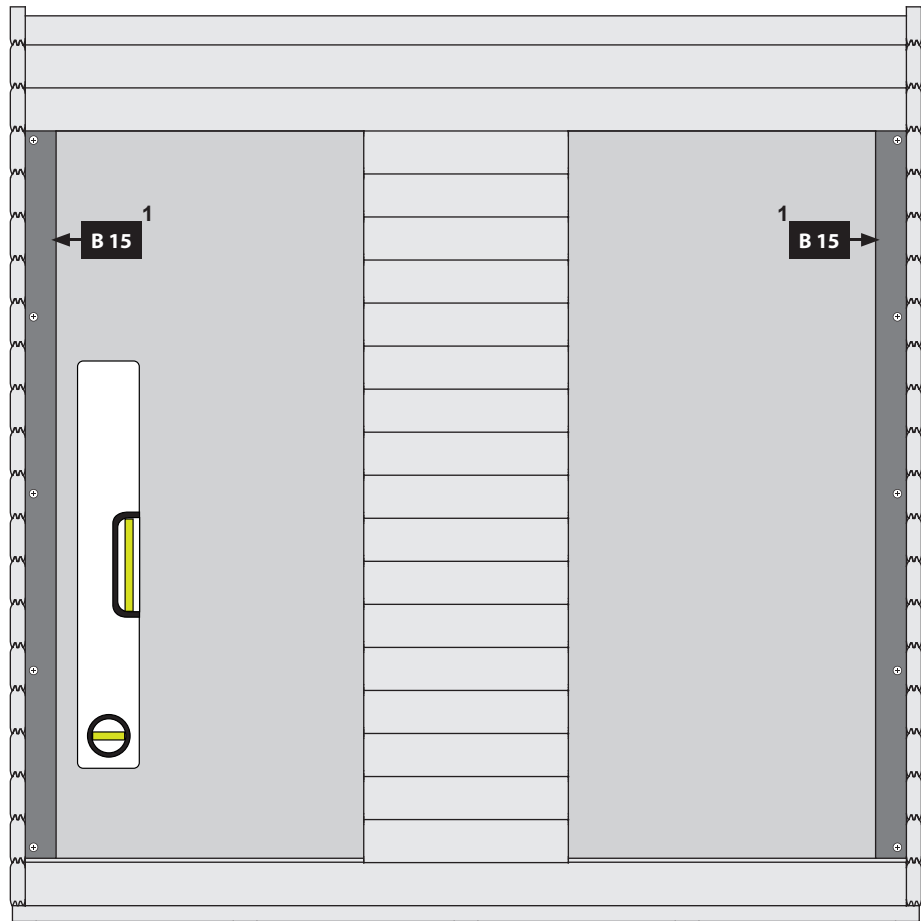
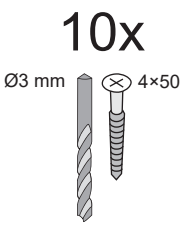
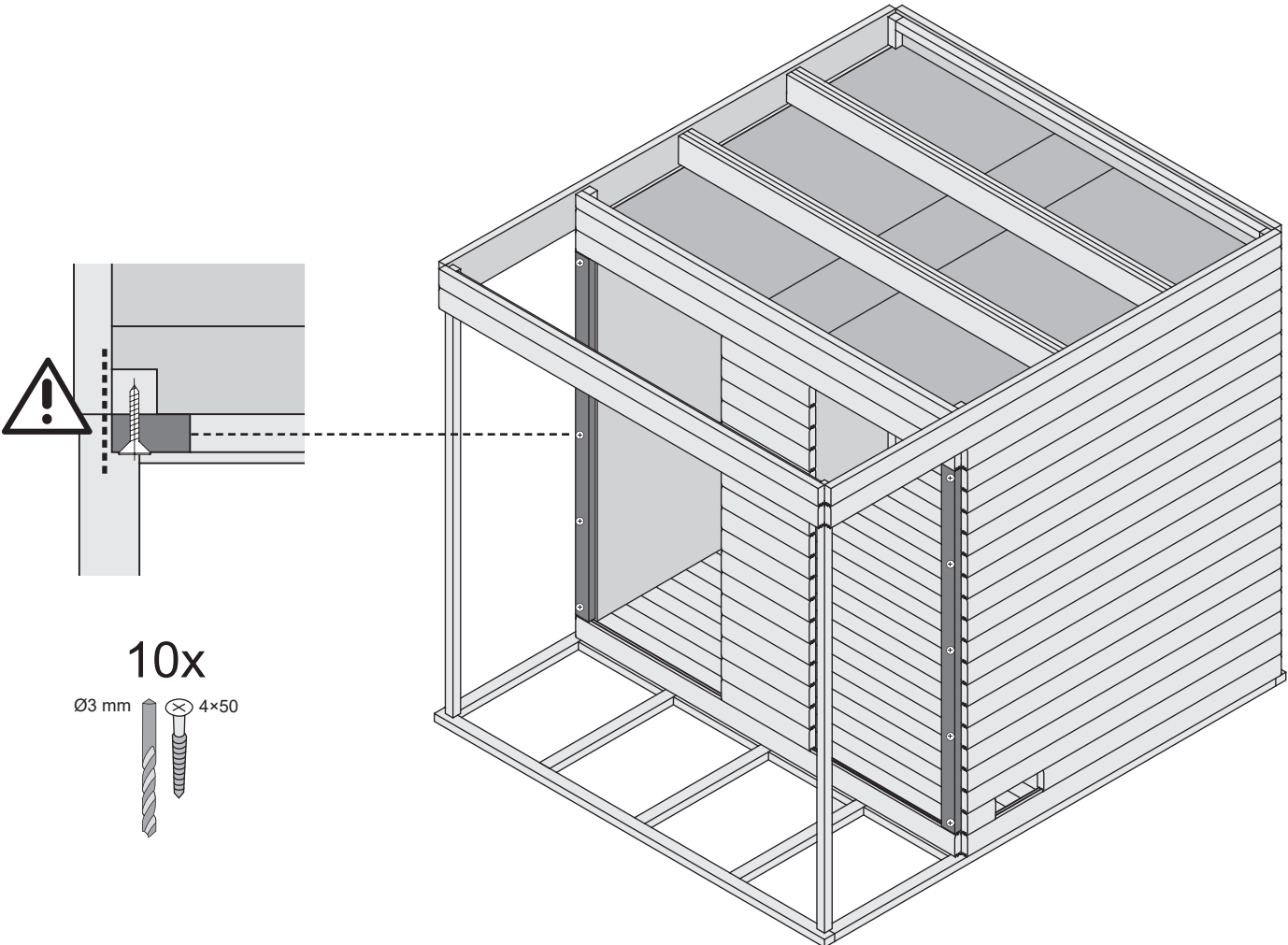

2x



100x

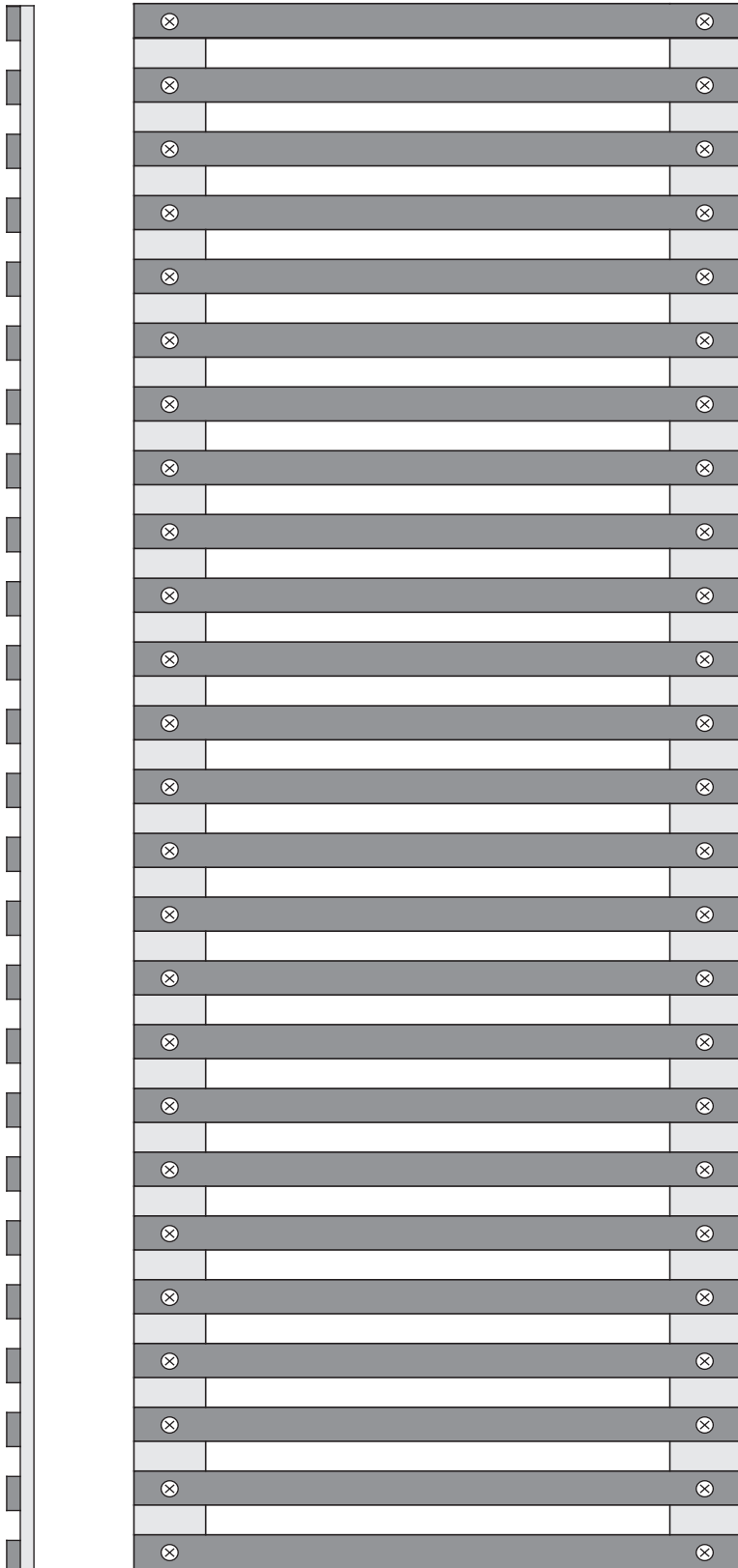
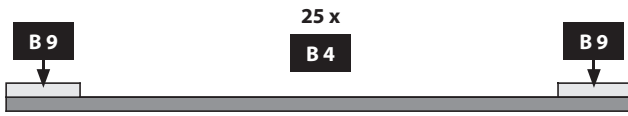
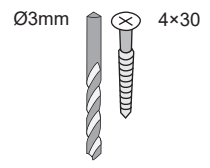

A ≈ 40 mm

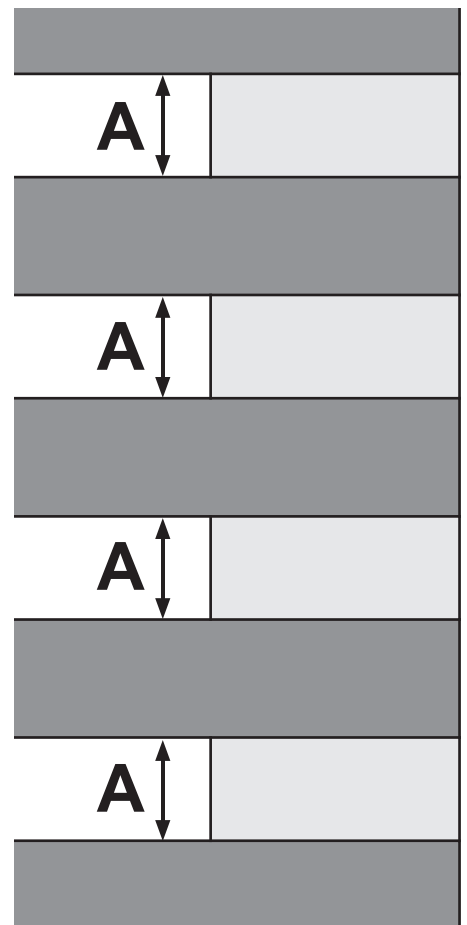

20x

Ø3 mm 4x50

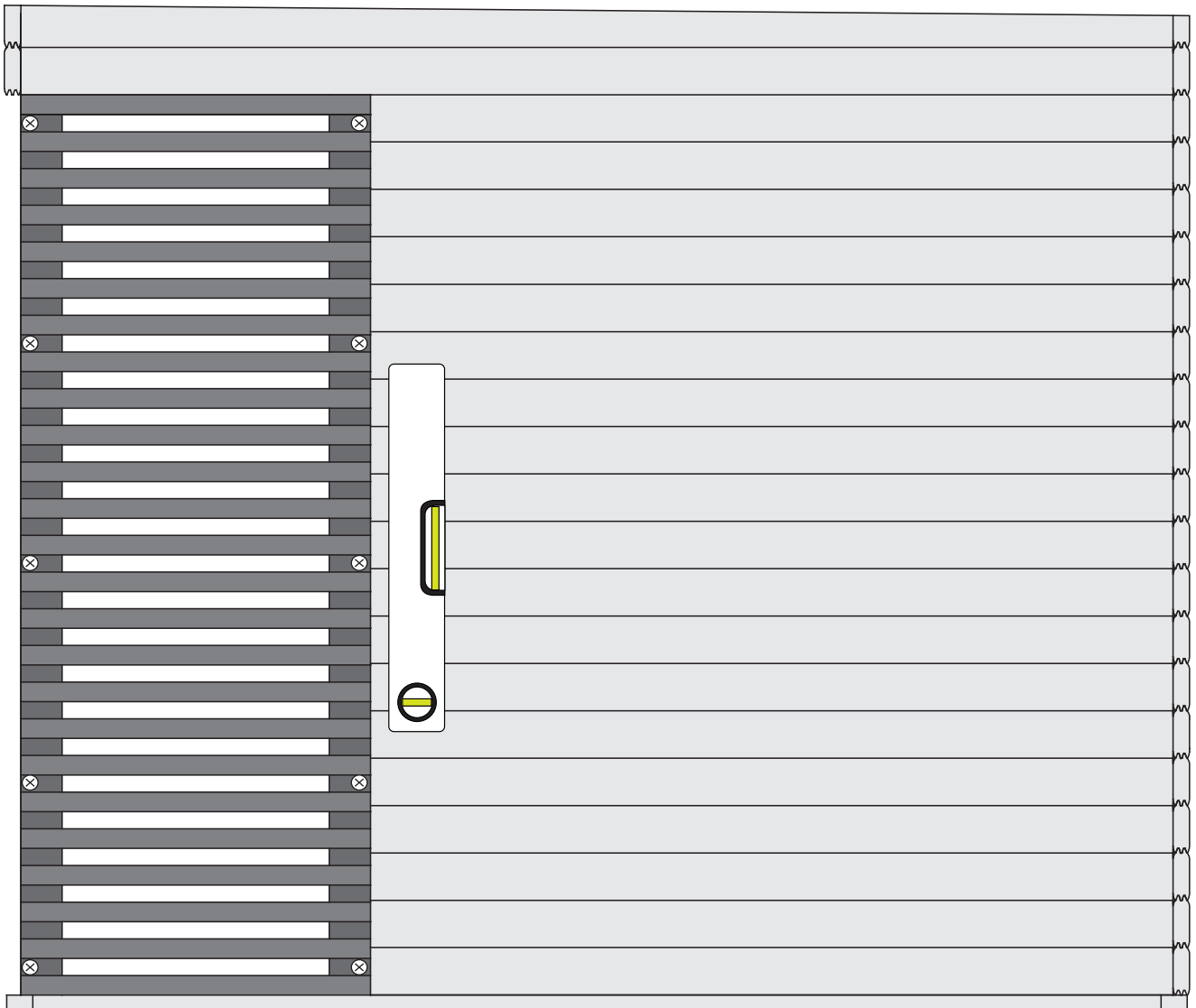
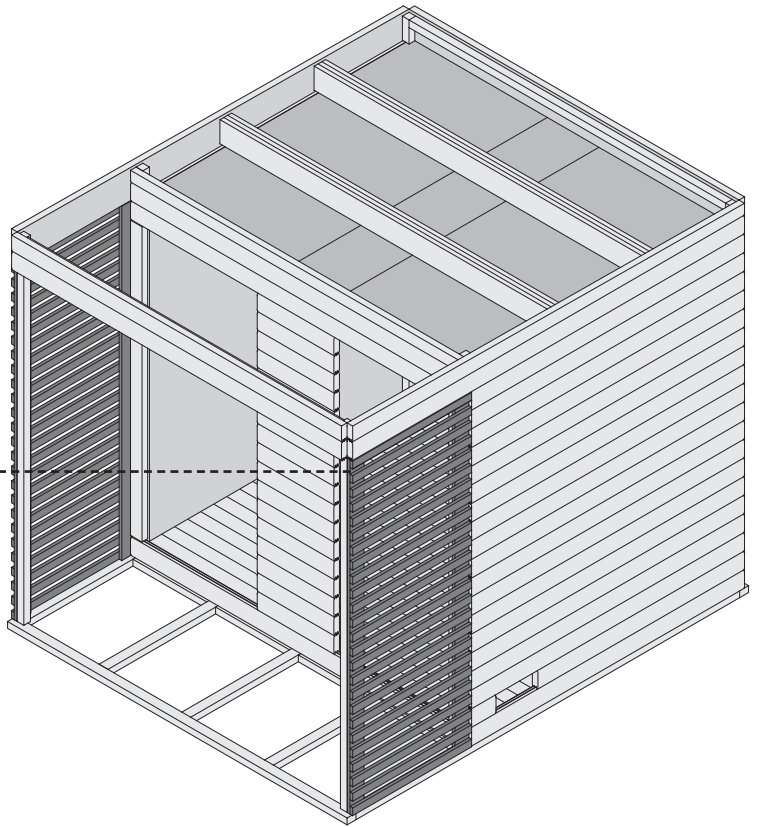
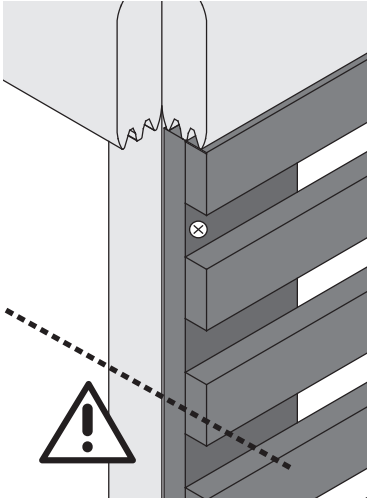
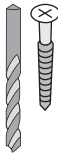

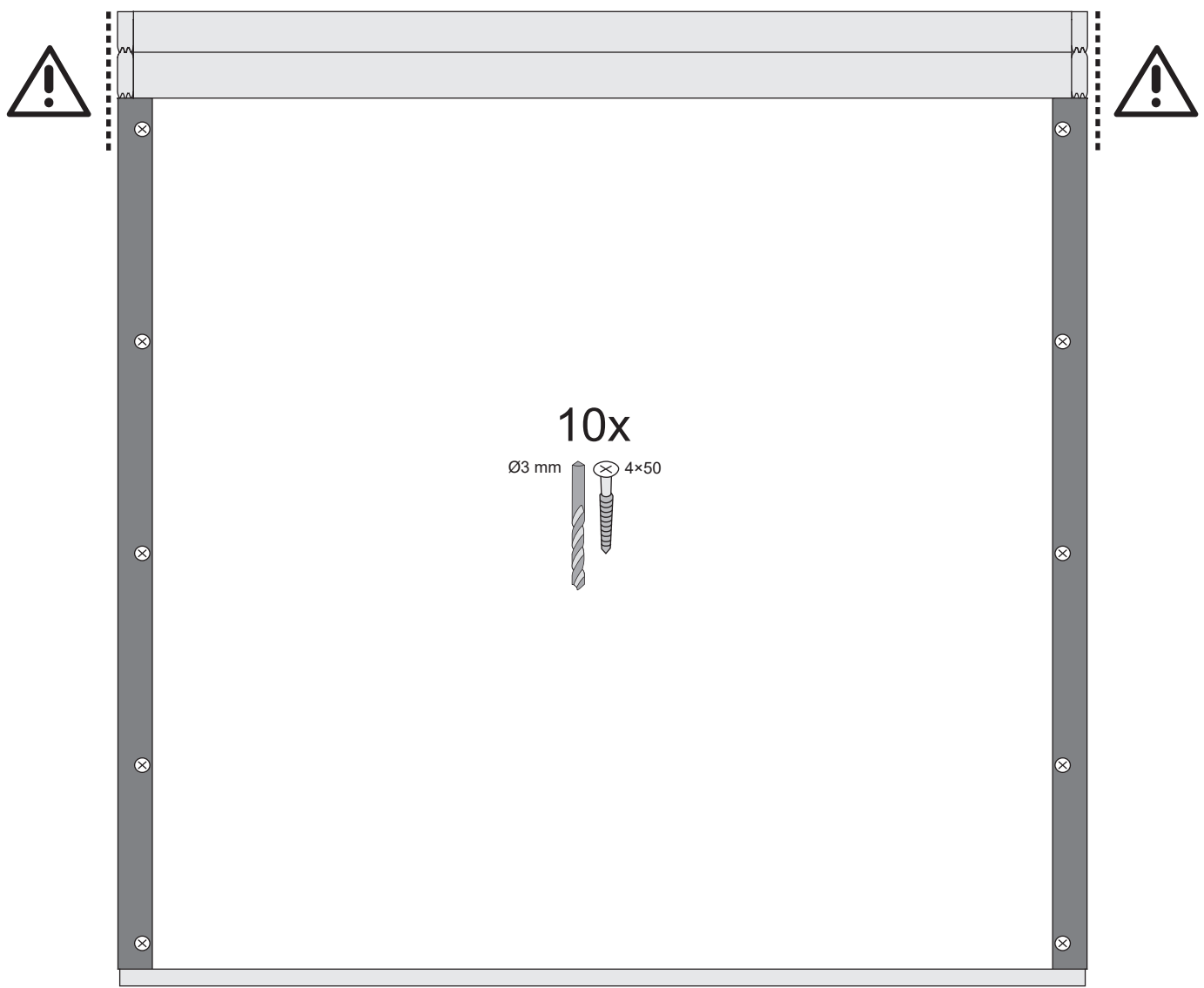
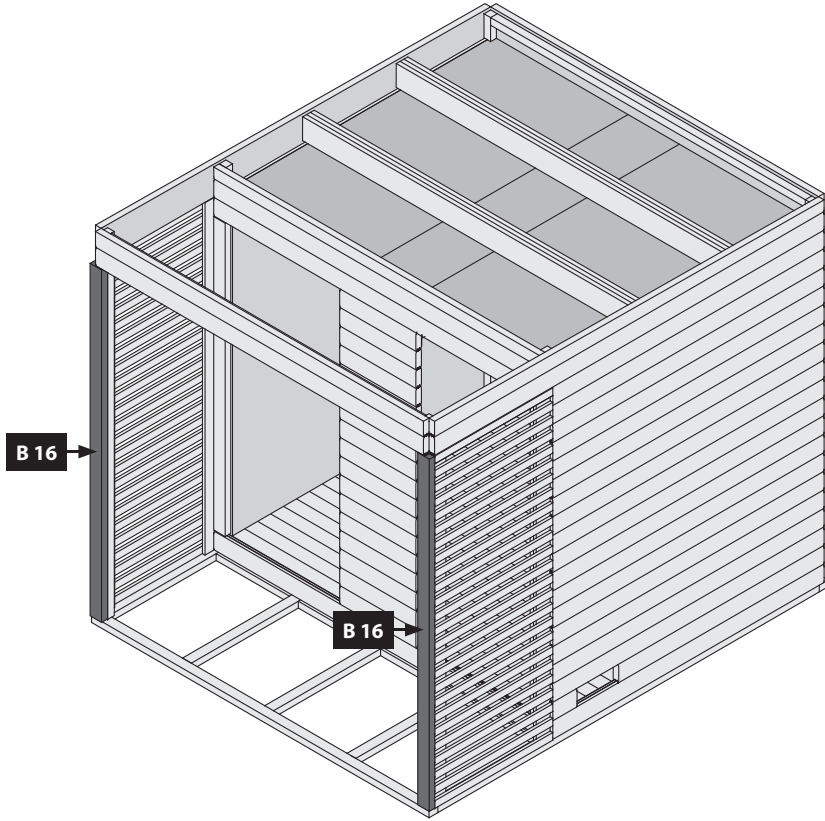

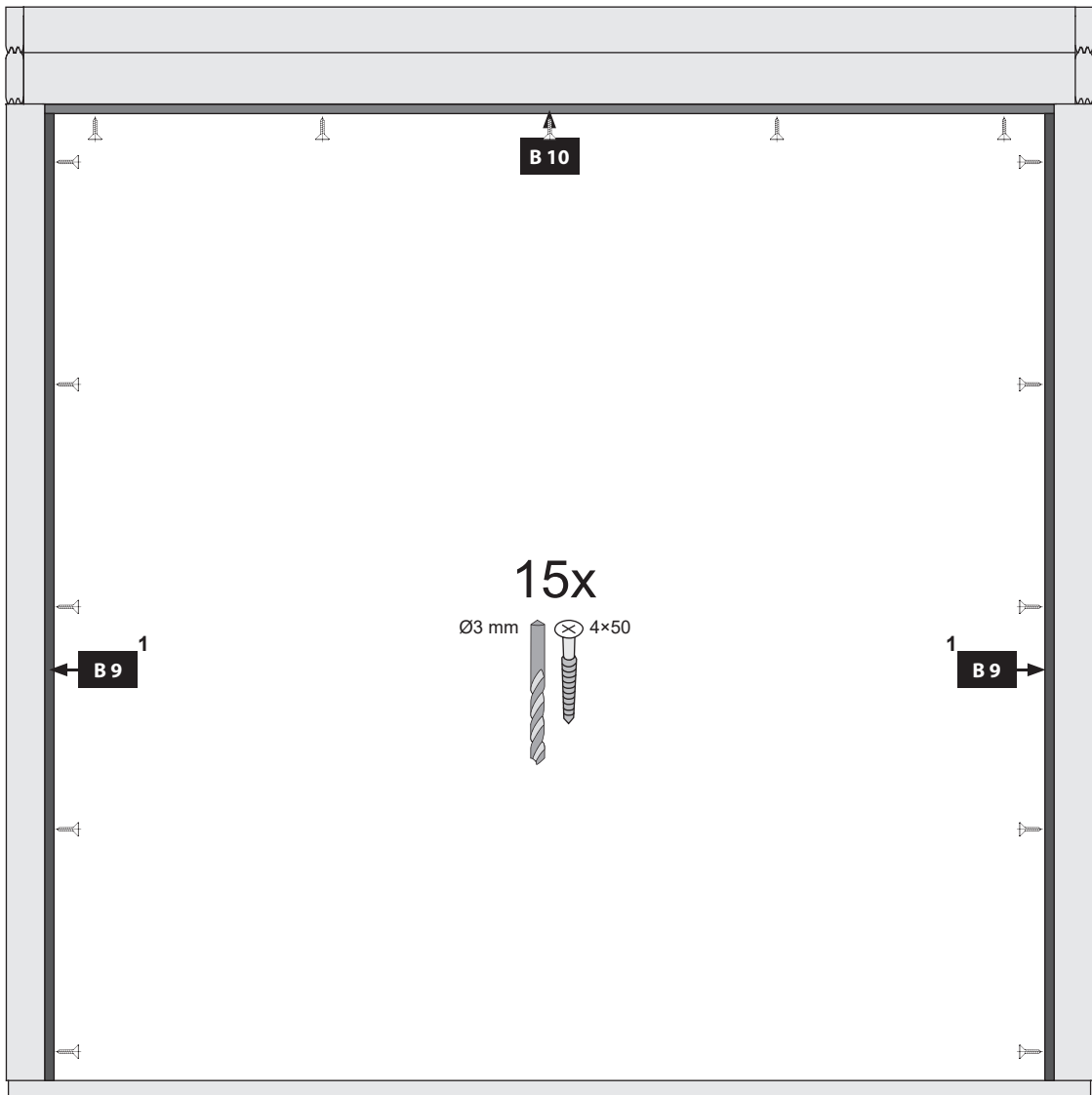
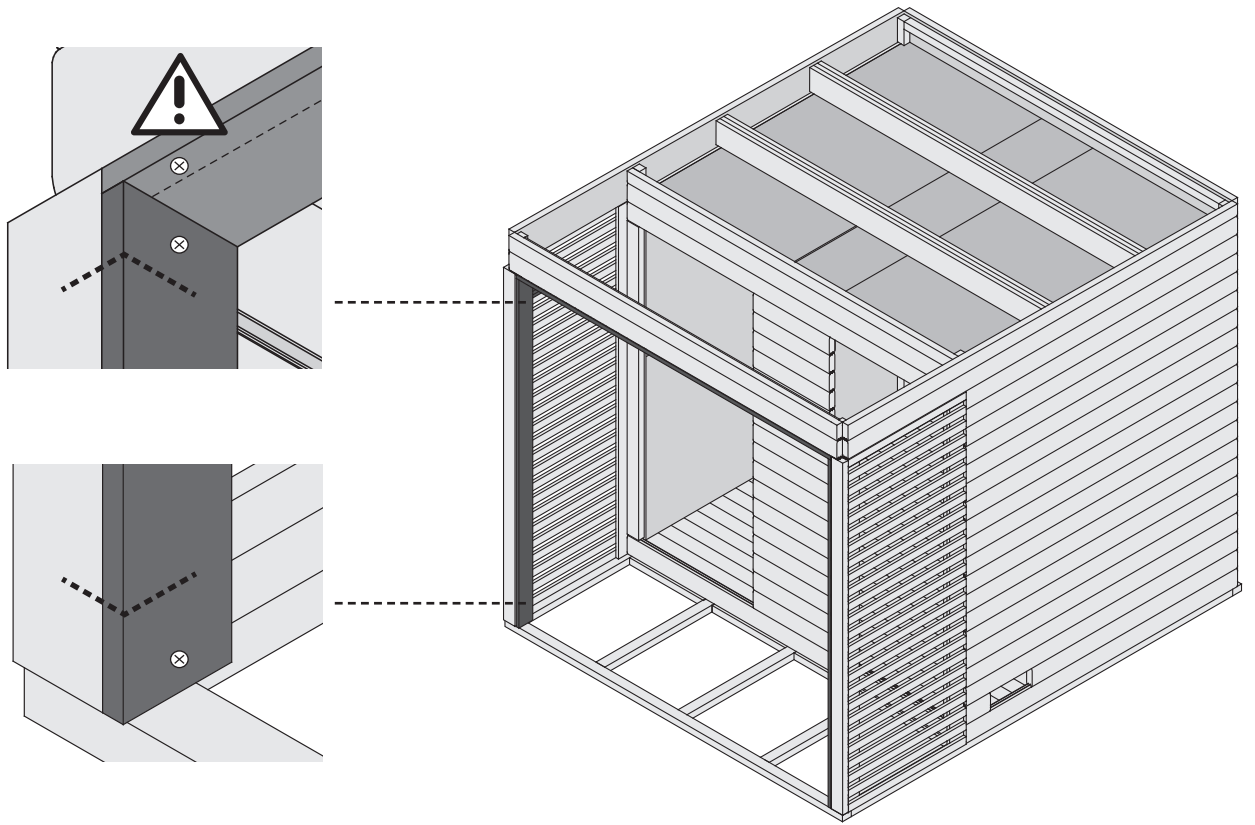

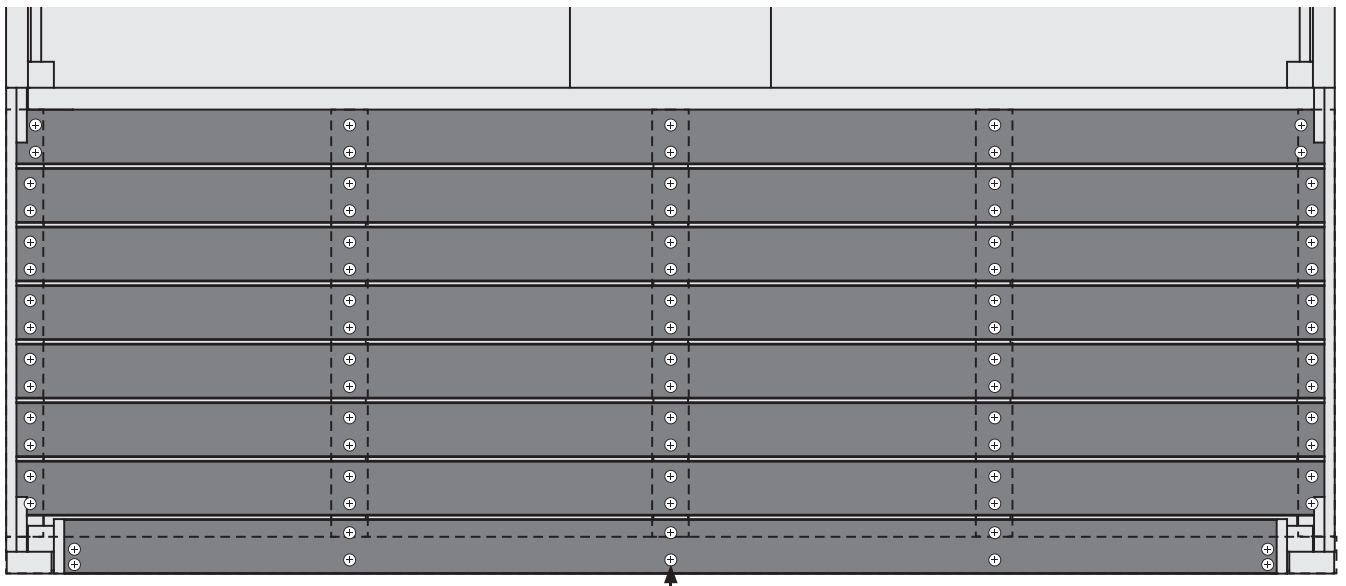
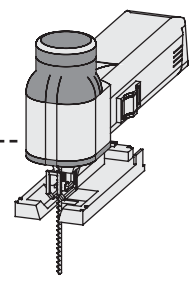
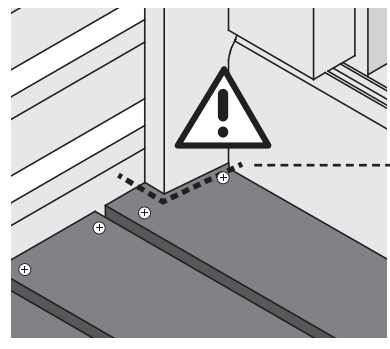
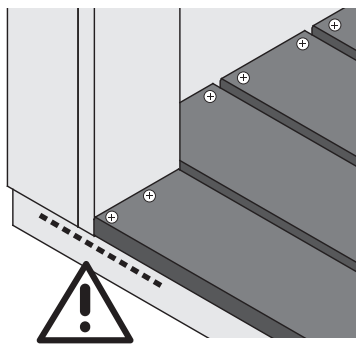
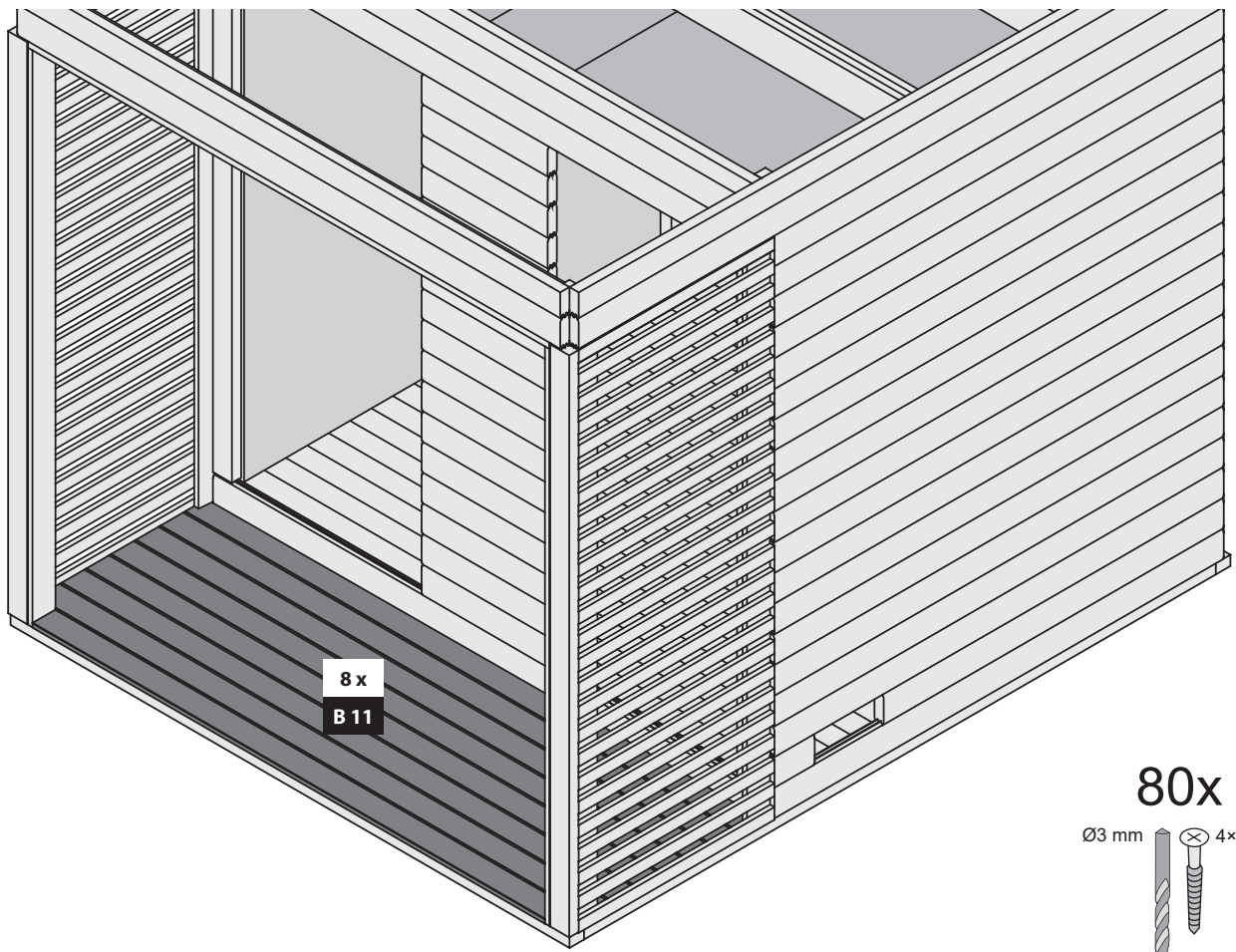

B 11
1

8x

Ø3 mm 4x30

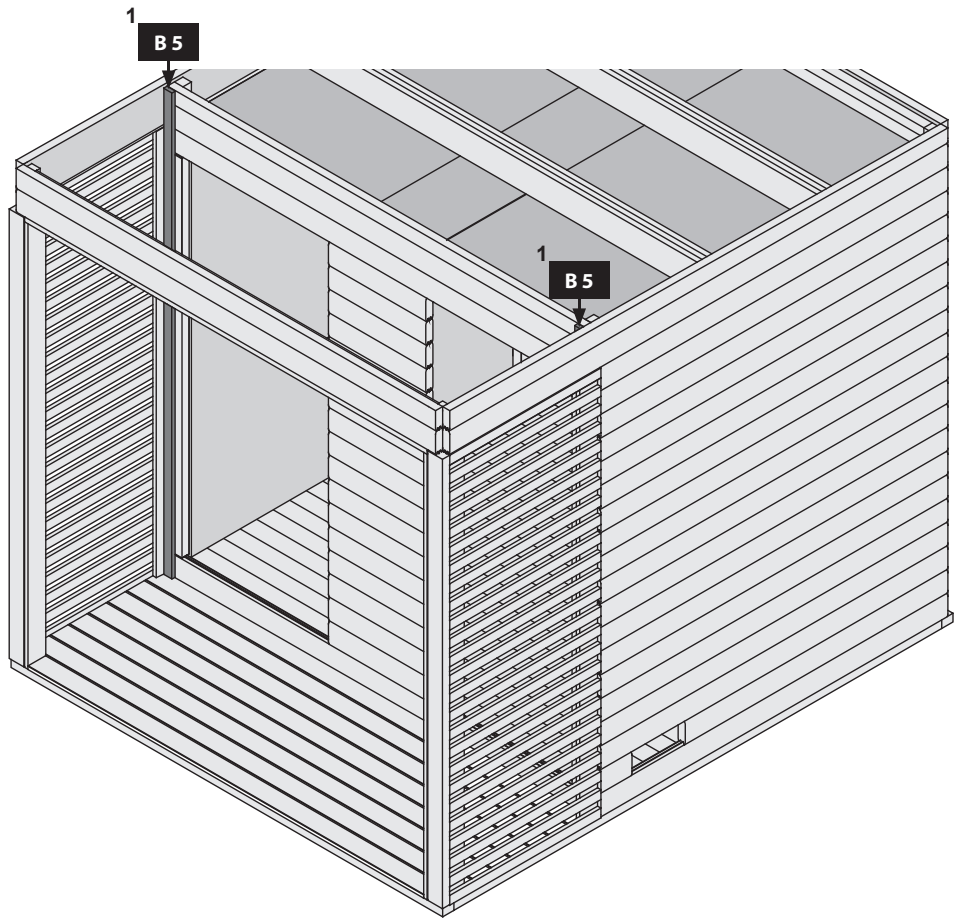
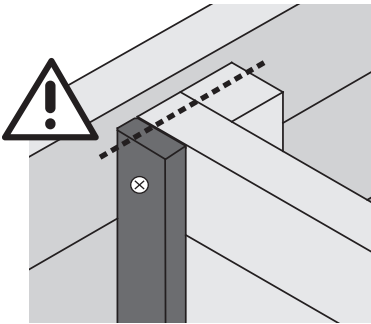
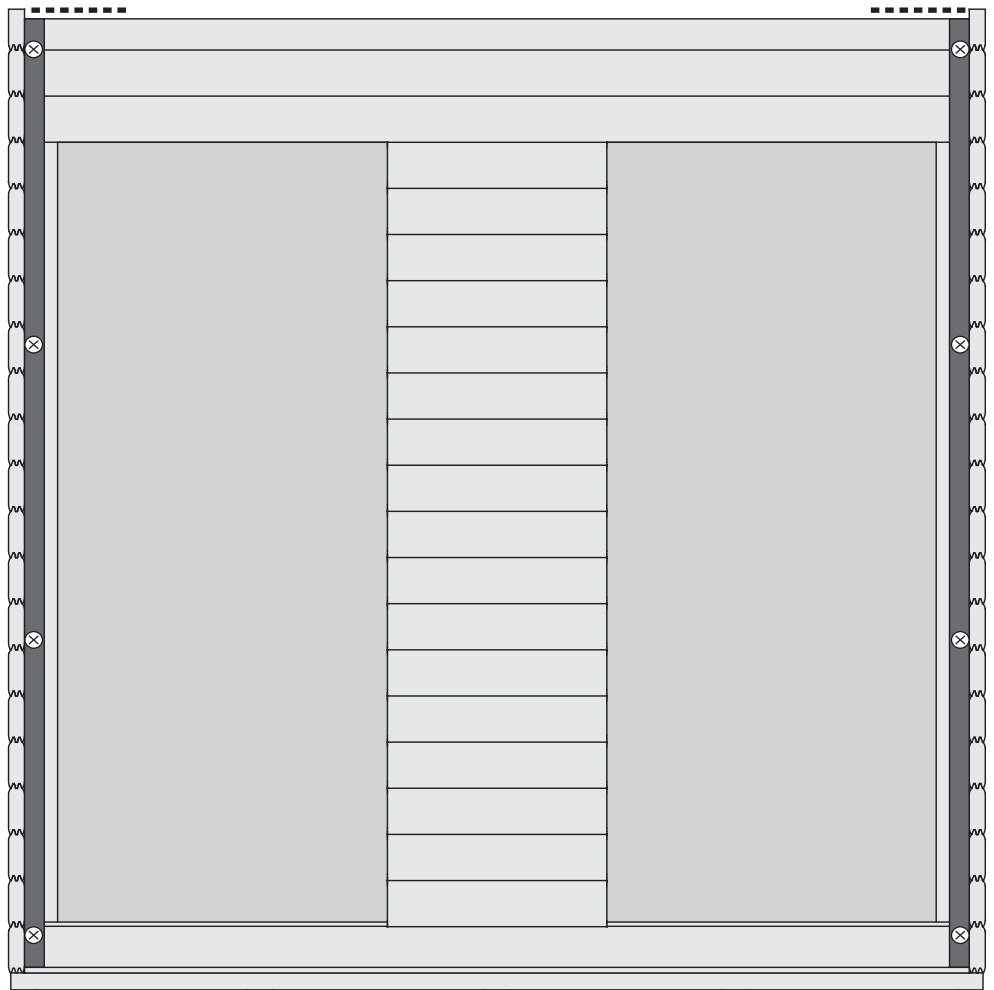
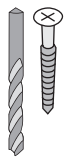

Exemplarische Kabelverlegung

Saunatyp 38/40 mm Fasshaus
Steuerung extern

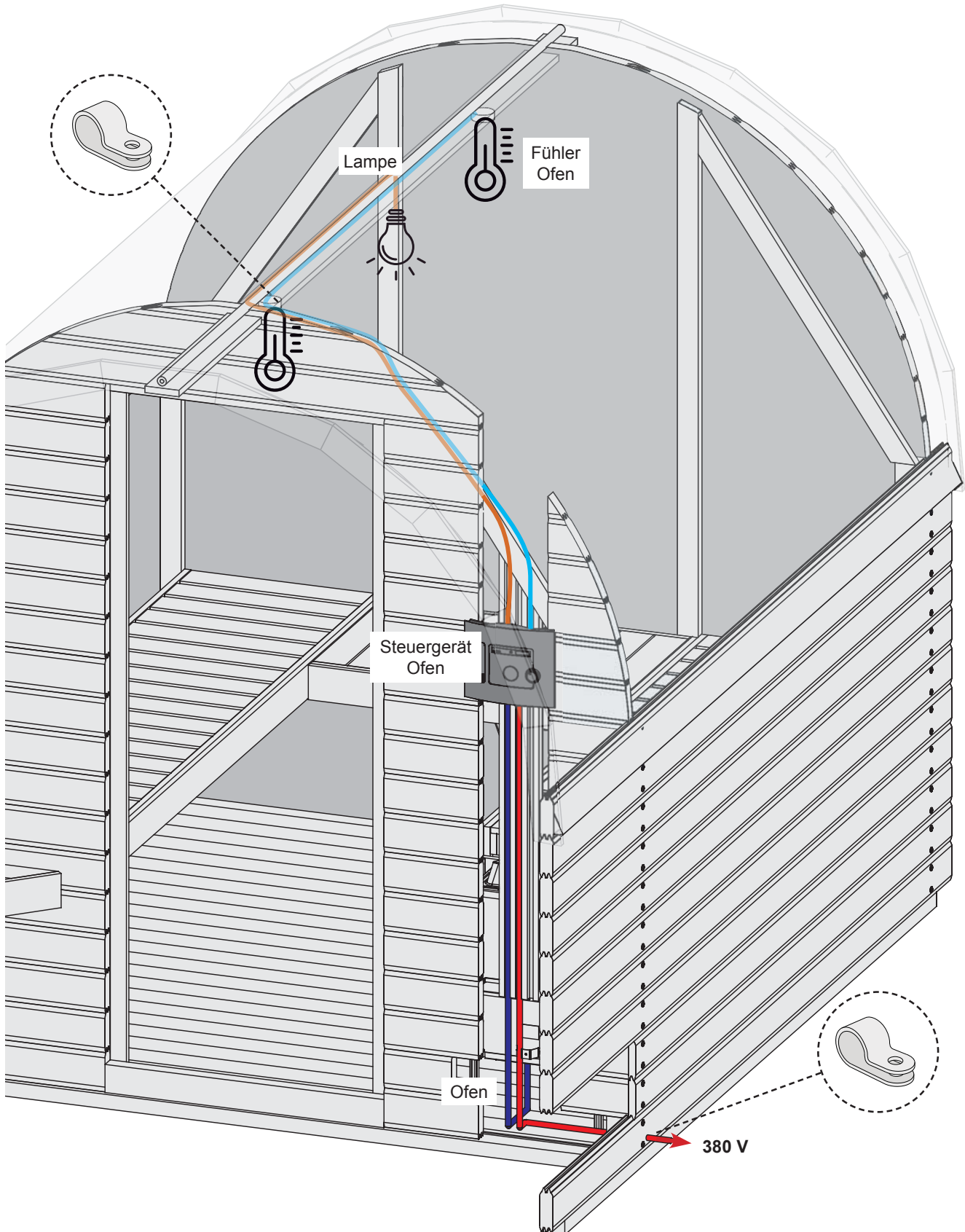
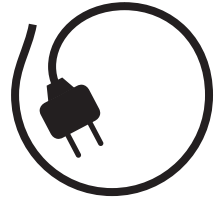
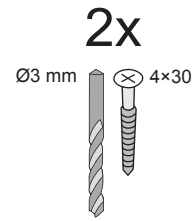

8x
Ø3 mm 4,5x50

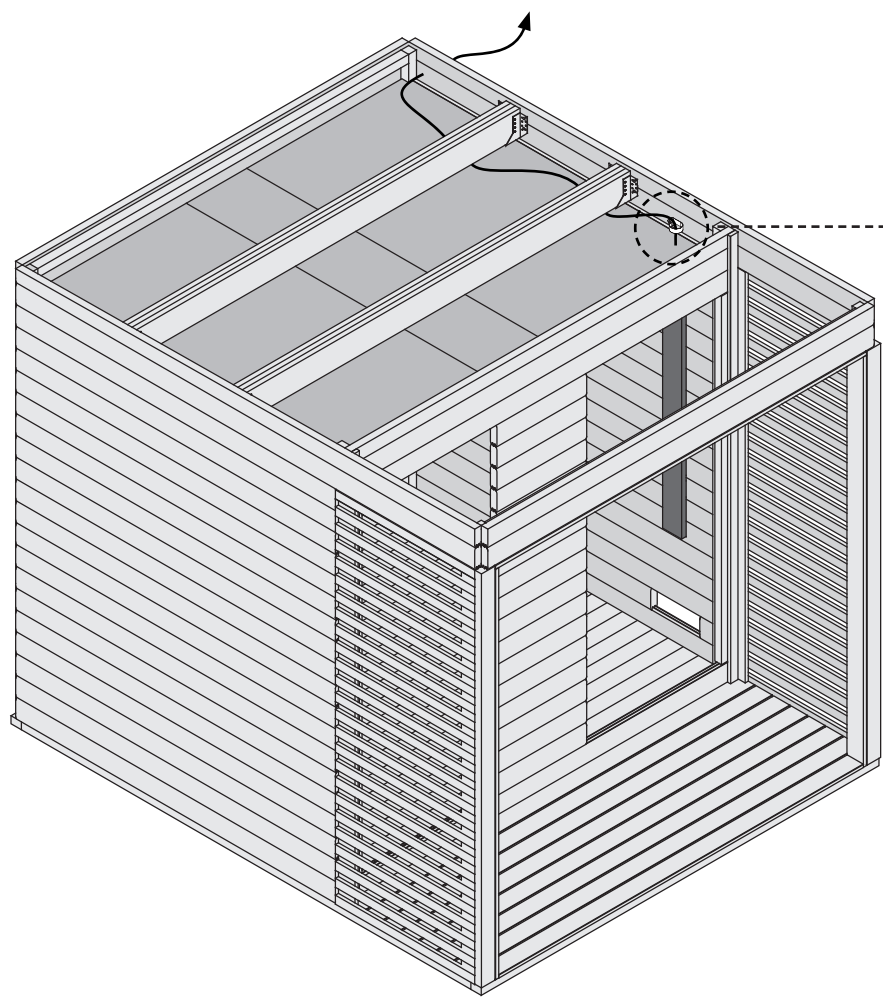
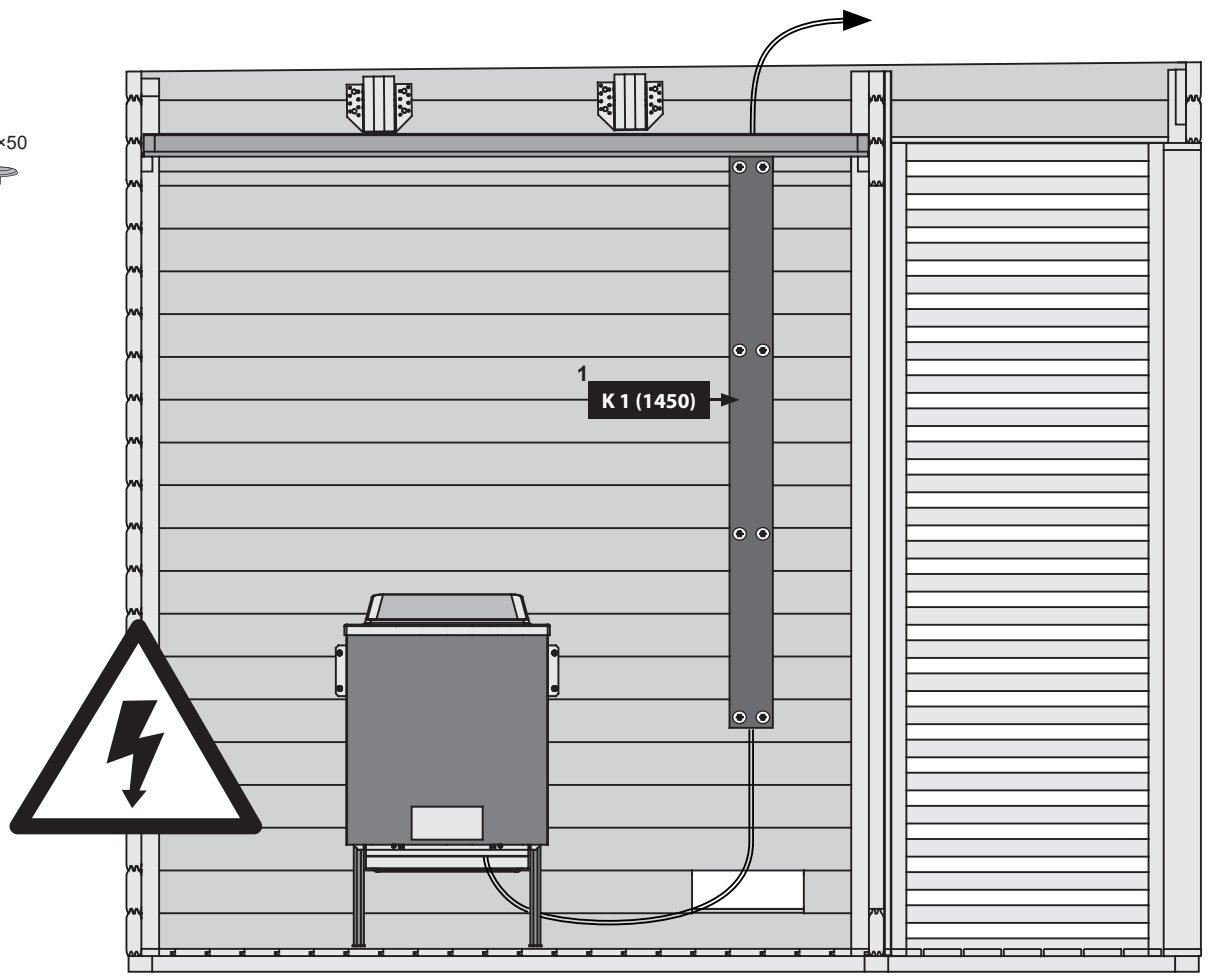

Ø2 mm 3x16
1x

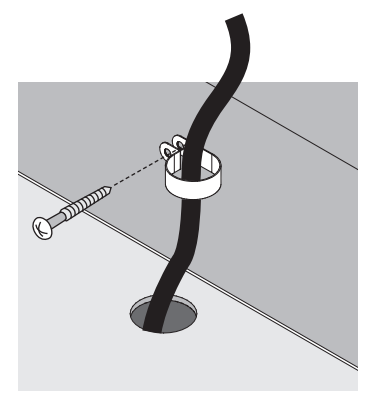
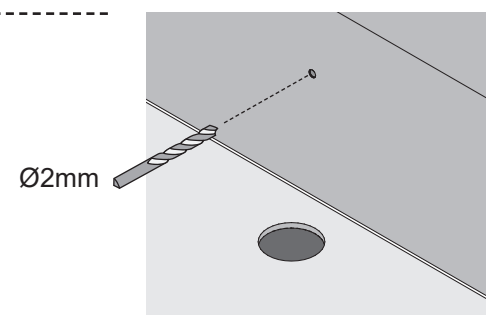

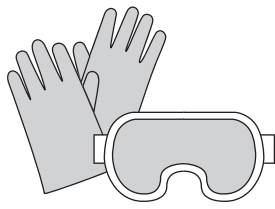

31

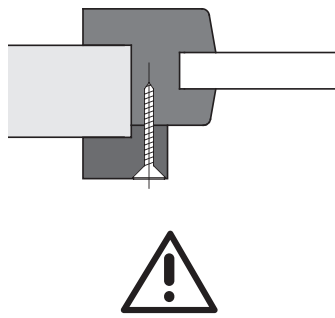
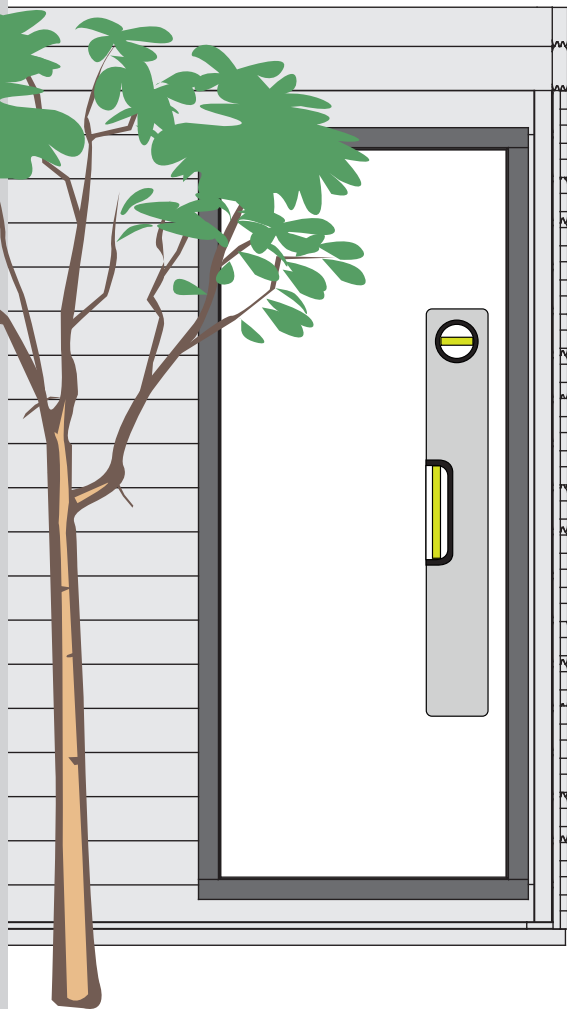
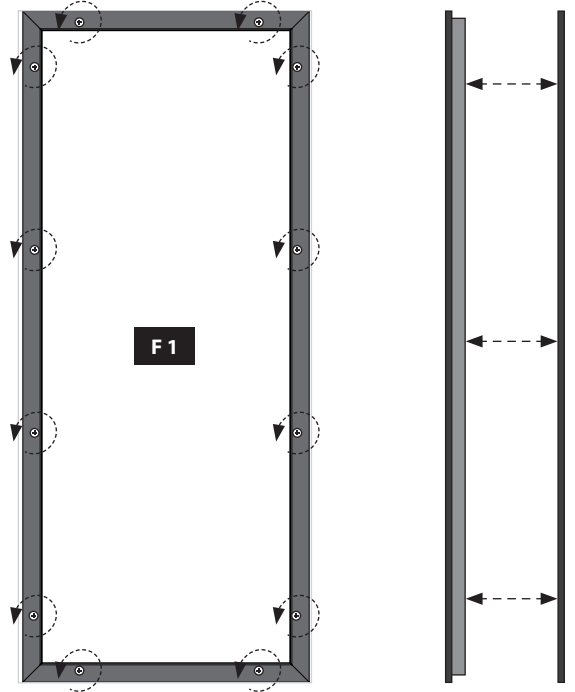
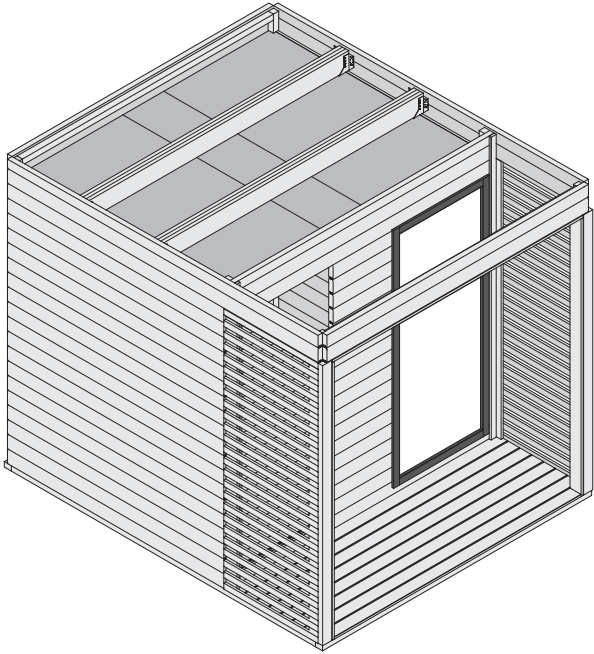

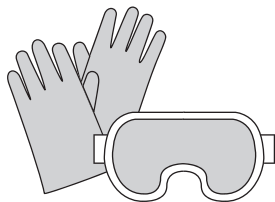

22x

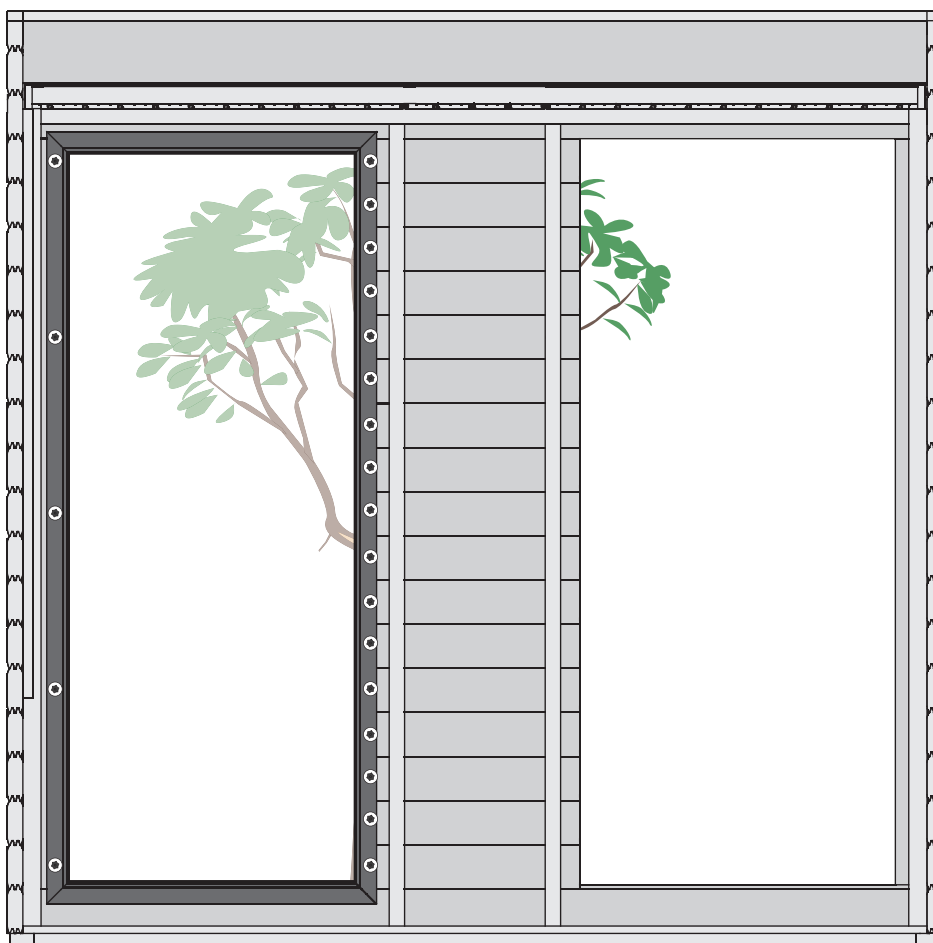
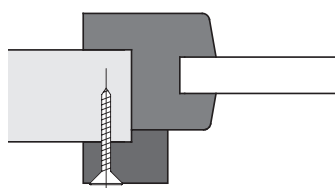
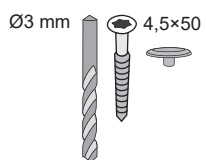

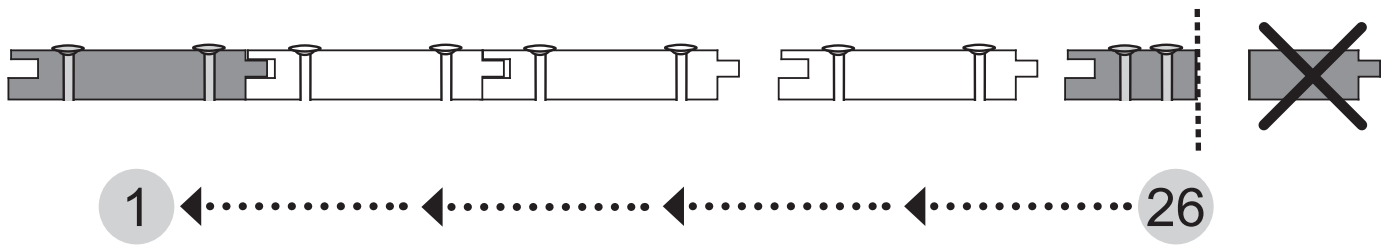
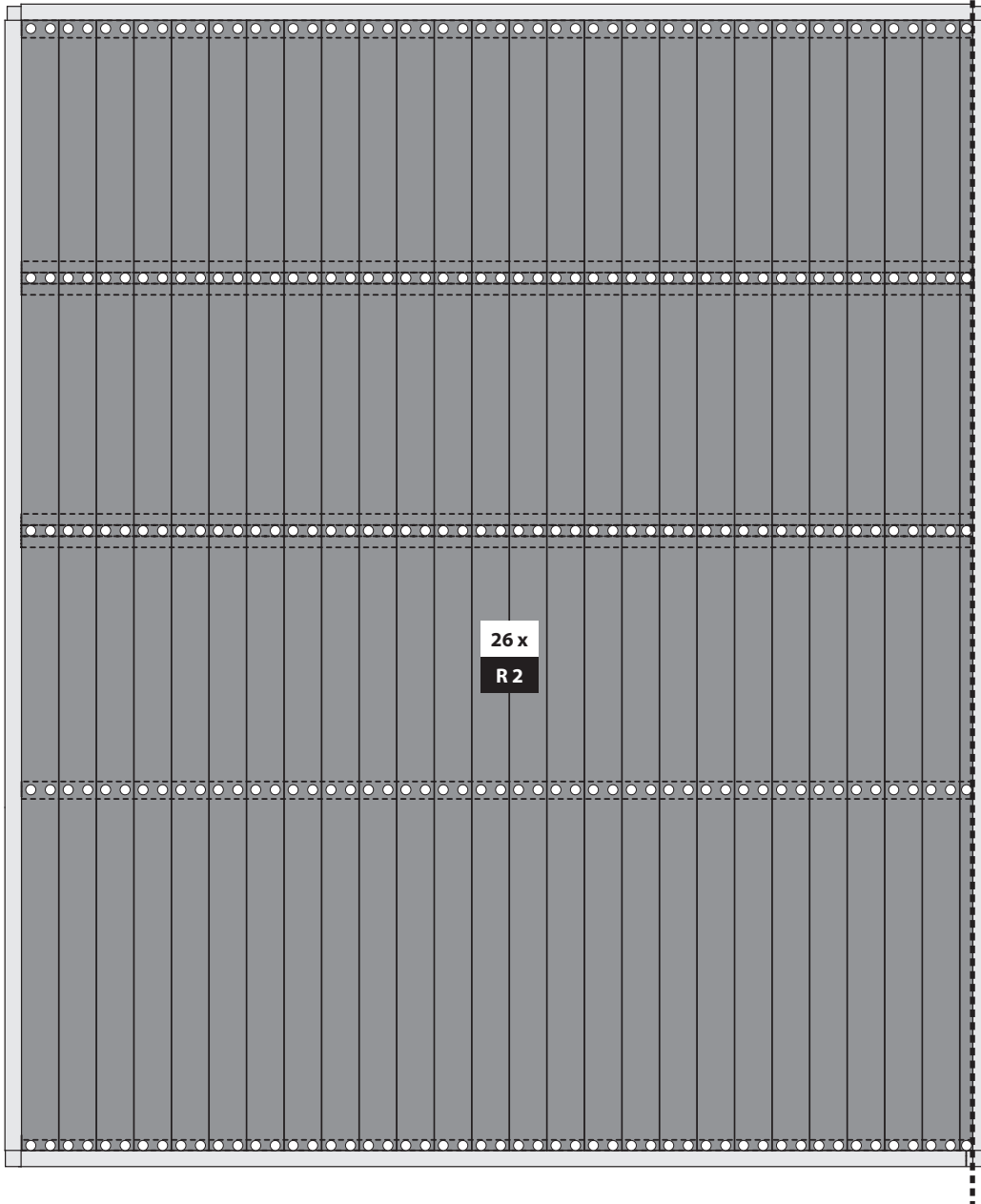
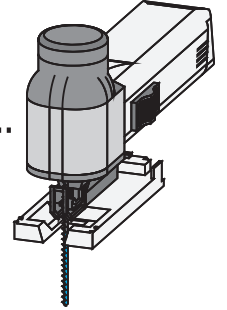
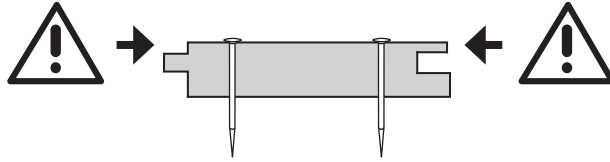
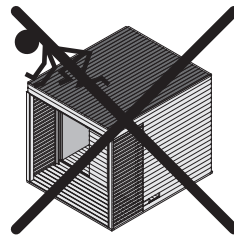
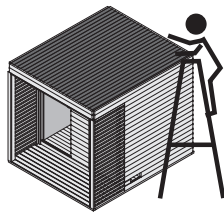



8x

Ø3 mm 4x30

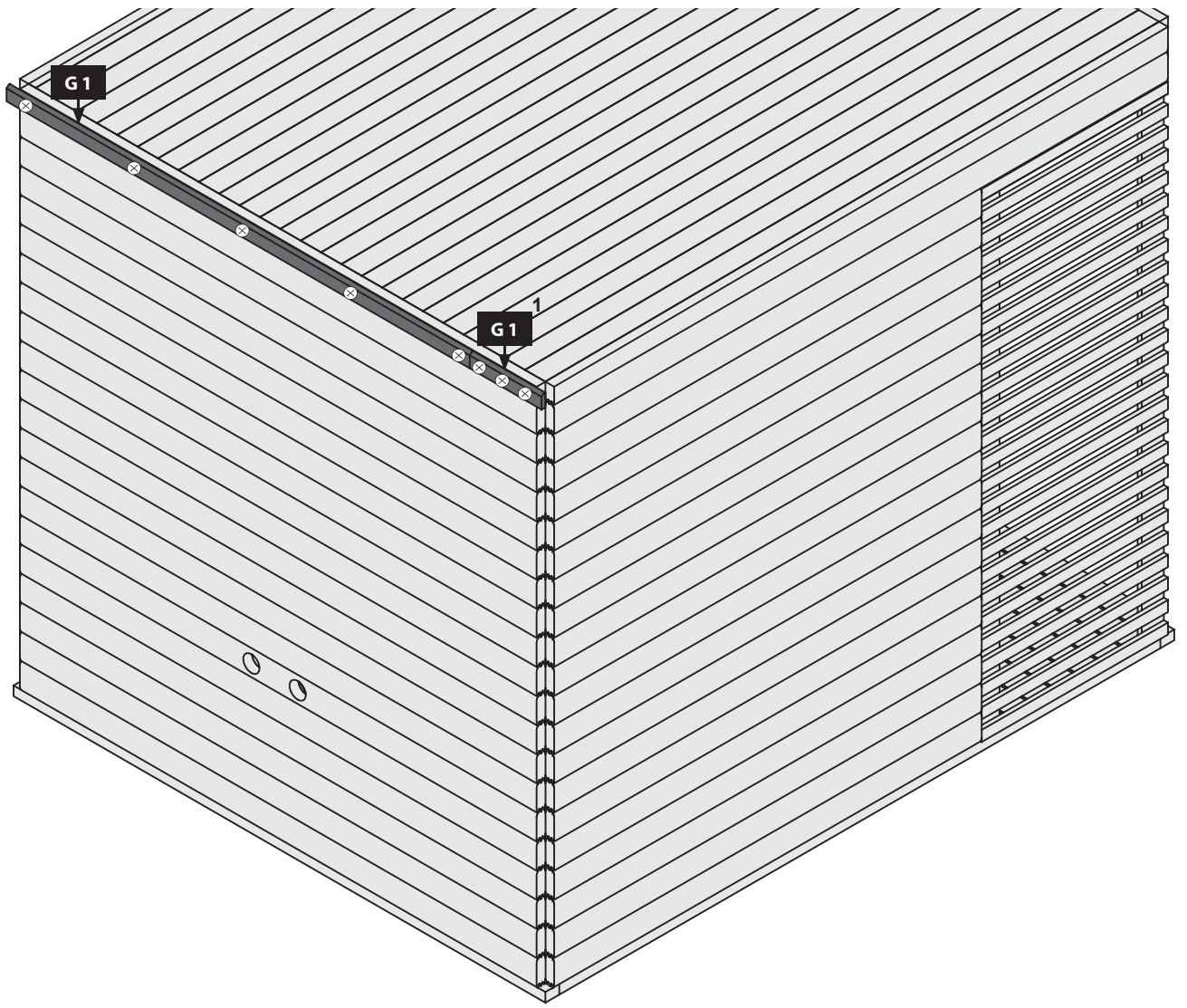
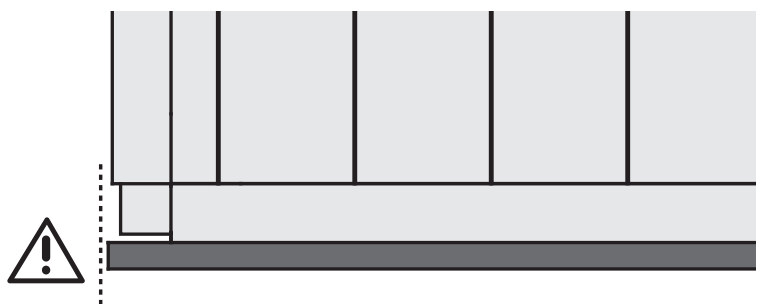
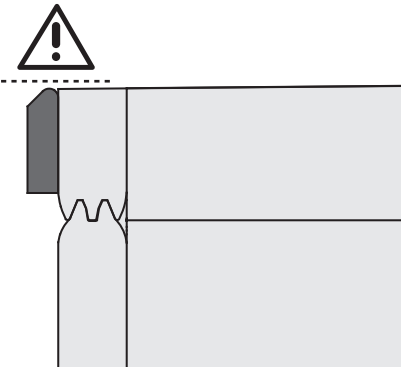
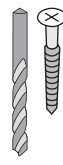

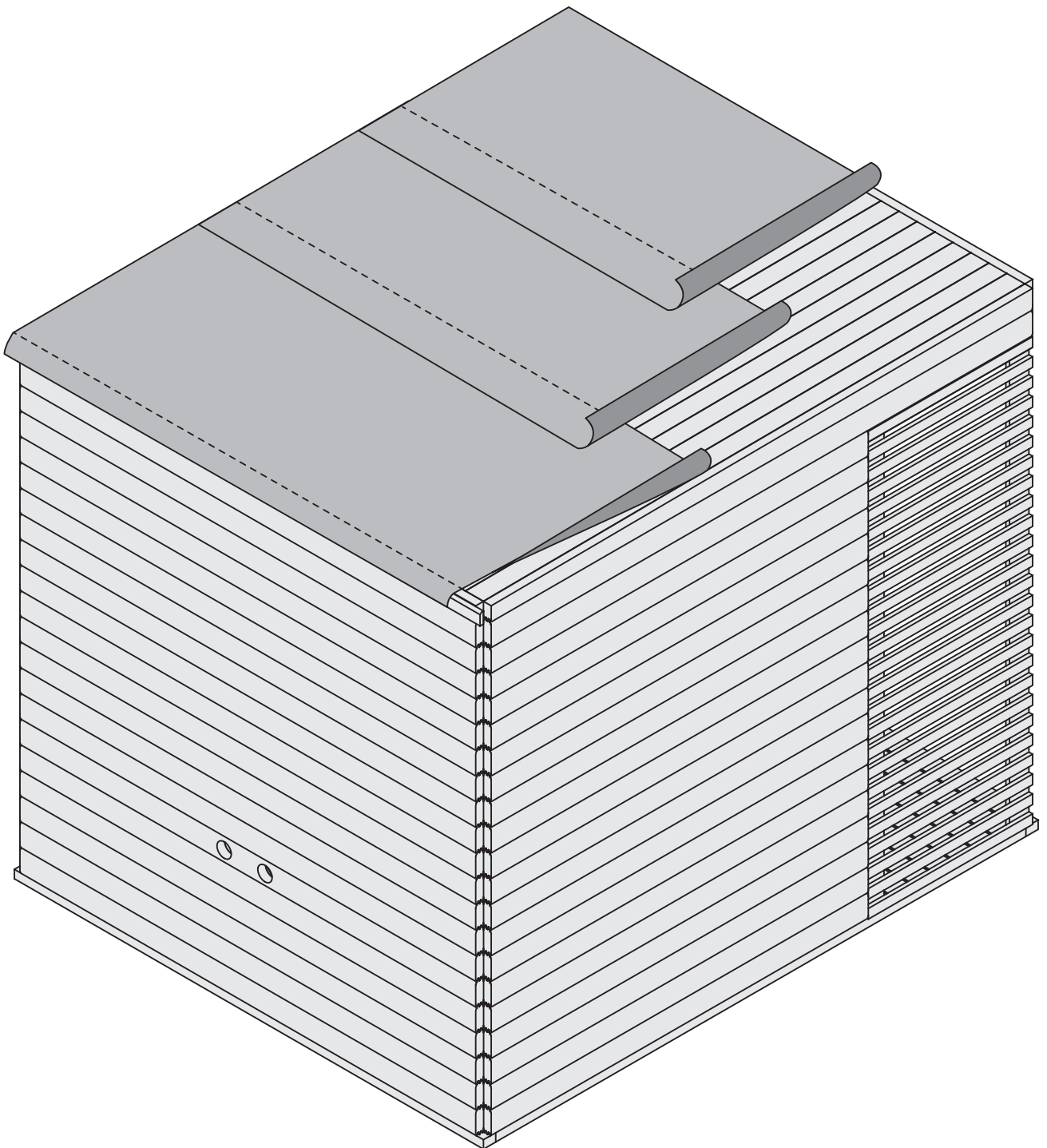
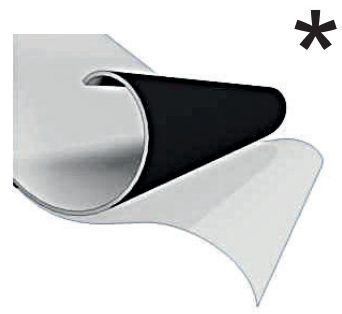
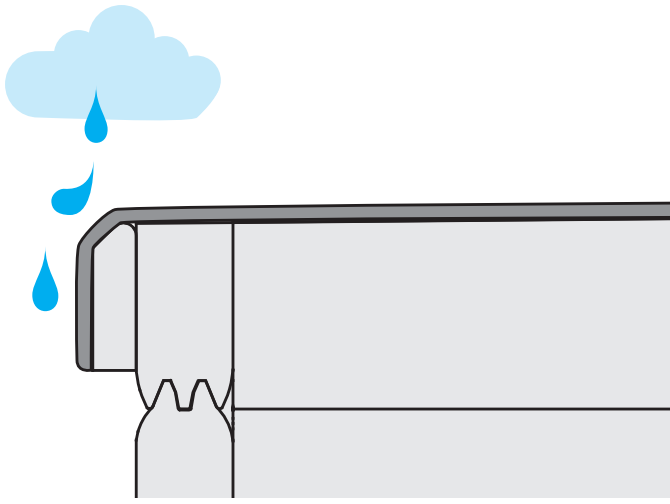

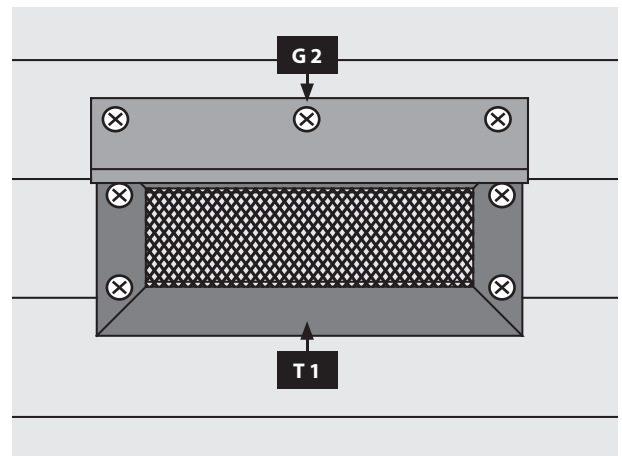
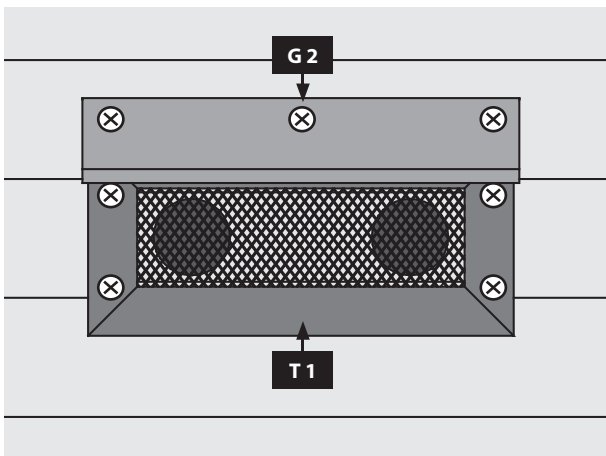
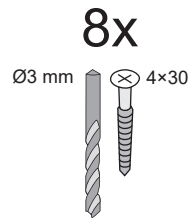
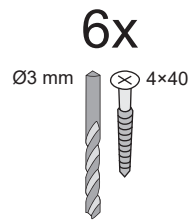
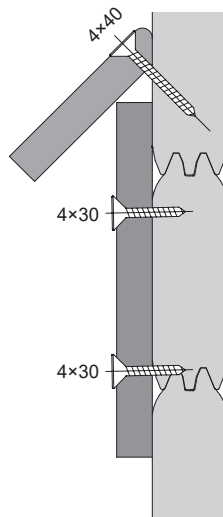
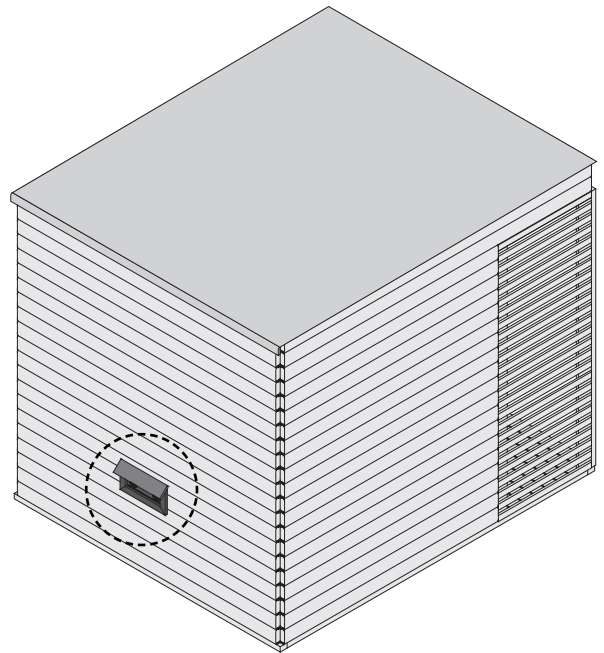
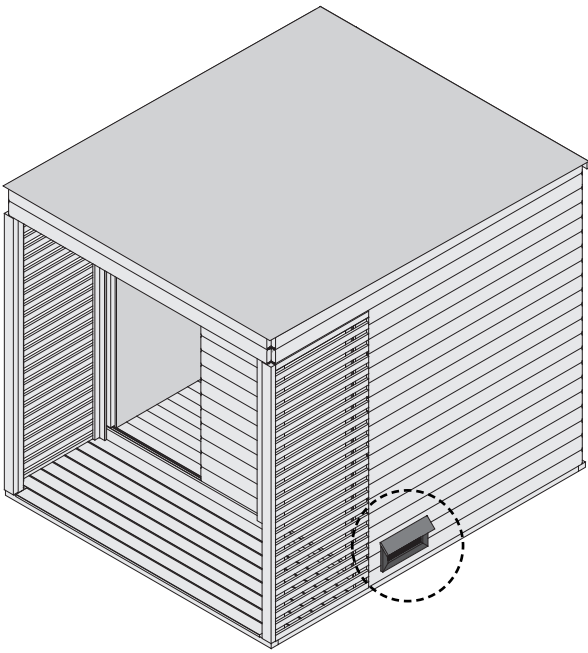

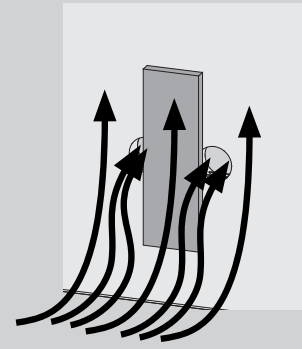
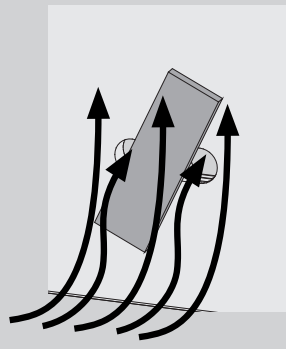
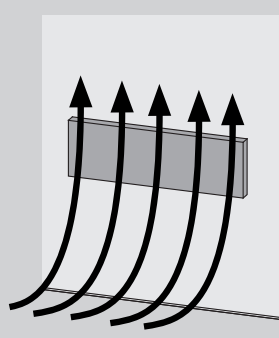
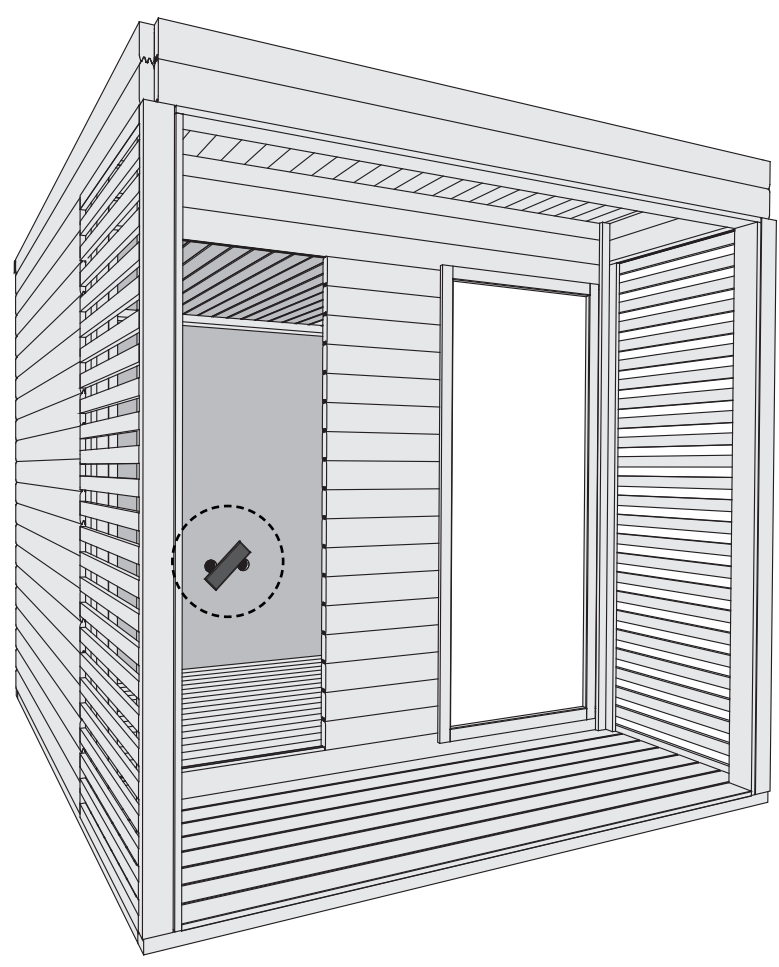
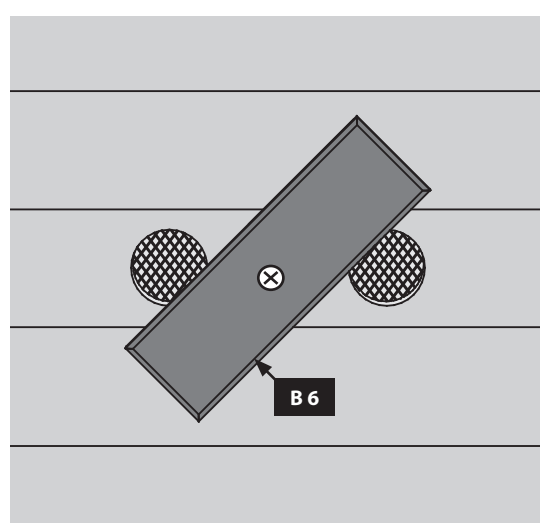
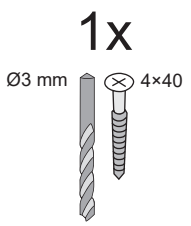





 Hier ist die Funktionsweise des Brettes abgebildet. Regeln Sie damit die Abluft nach Ihren eigenen Wünschen

 This figure shows the functional principle of the board. Regulate the exhaust air according to your own wishes

 Ceci représente le mode de fonctionnement de la planche. Avec elle, réglez l'écoulement de l'air selon vos désirs.

 Hier is de werking van het plankje afgebeeld. Regel daarmee de luchtafvoer naar eigen wens

 Sådan fungerer styret. Brug den til at regulere udstødningsluften efter dine egne ønsker

 Aquí está representada la forma de funcionamiento de la tabla. Regule con ello el aire de salida según sus propios deseos

 Viene illustrato il principio di funzionamento della tavoletta di regolazione della ventilazione. Con essa si può regolare a piacere la ventilazione

 Zde je zobrazená funkce desky. Regulujte s ní odsávací vzduch dle Vašeho přání

 Tukaj si lahko ogledate delovanje plošče. Z njo lahko uravnavate izpušni zrak po lastnih željah.

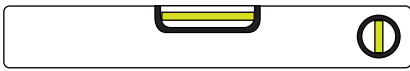
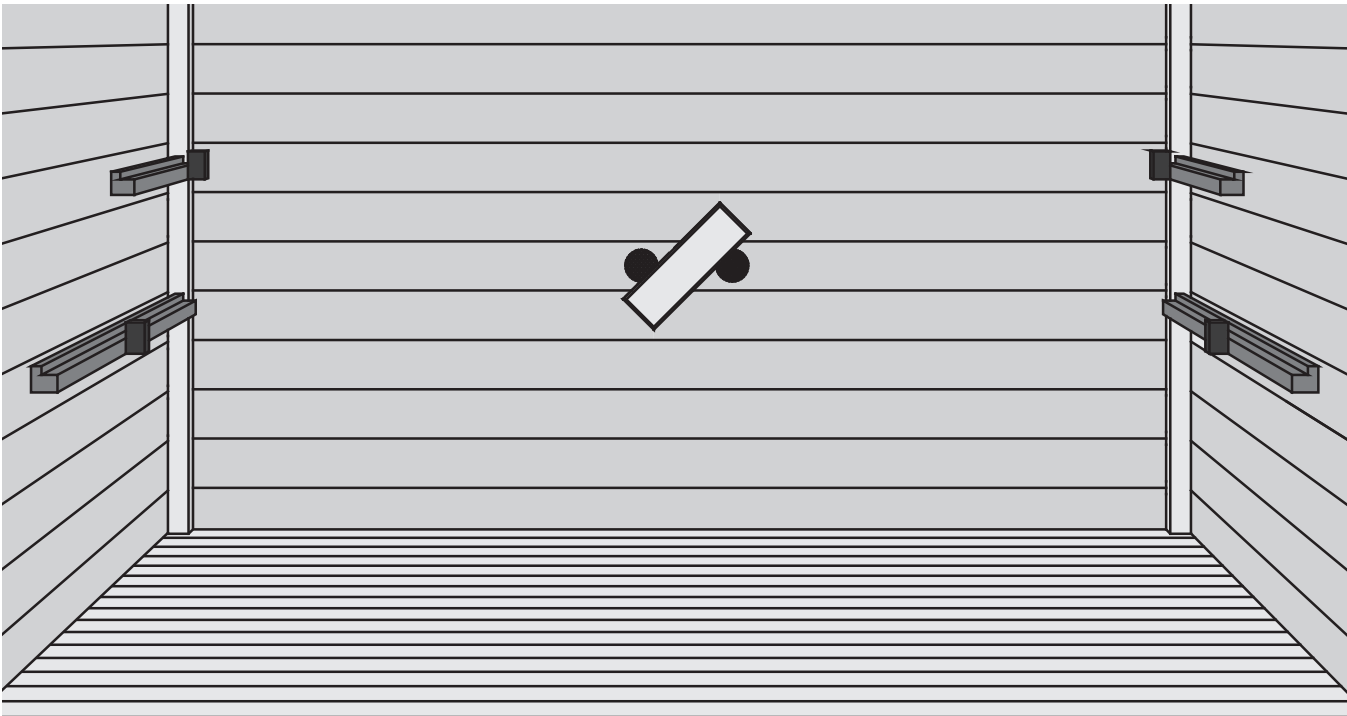

26x

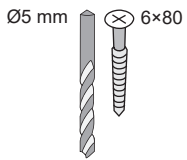



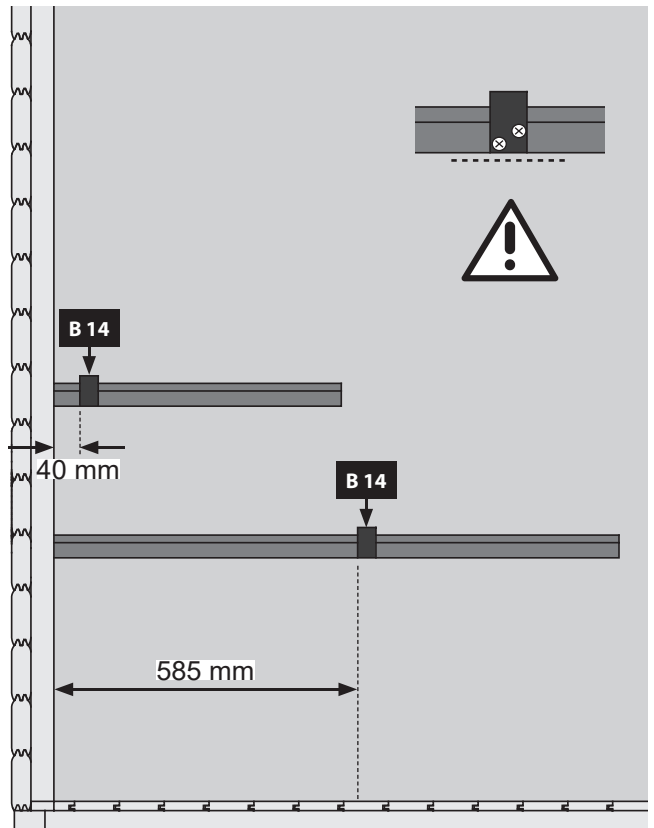
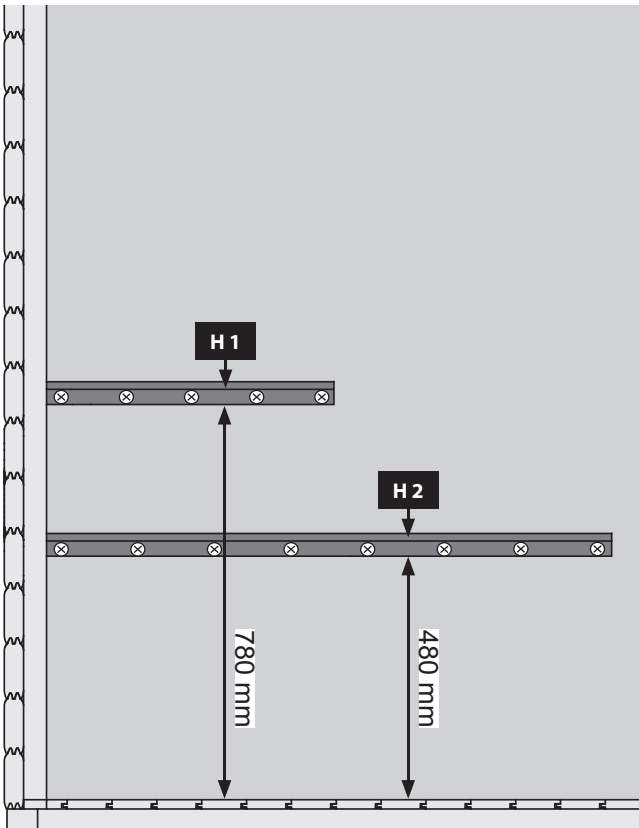
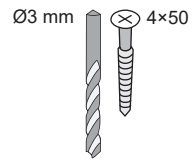

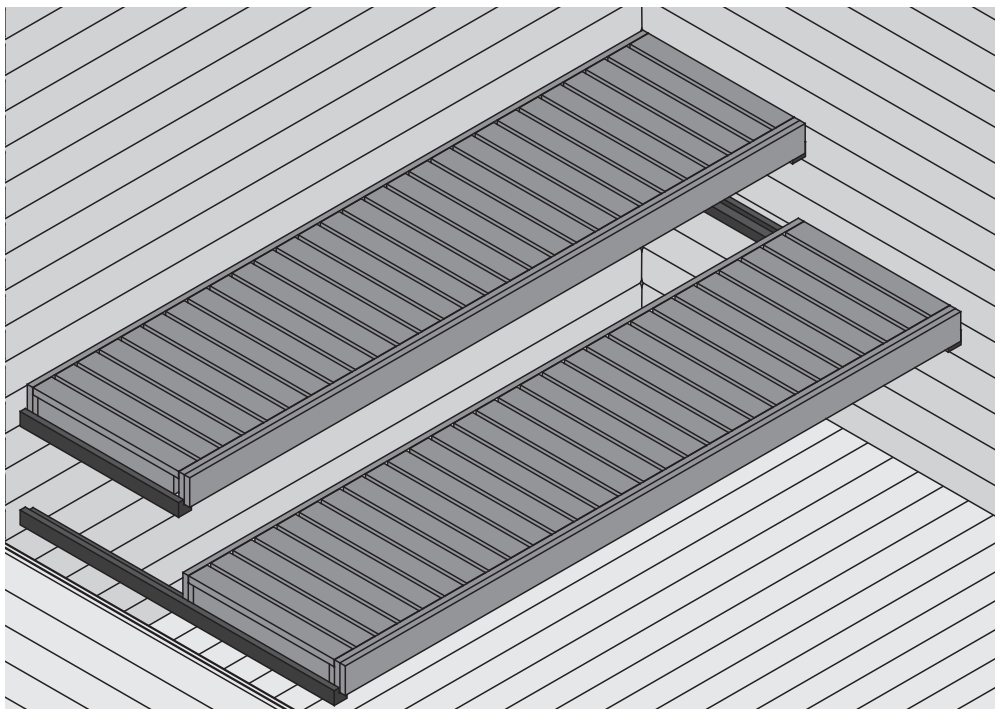
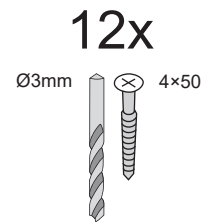
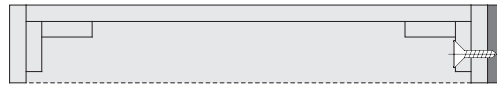
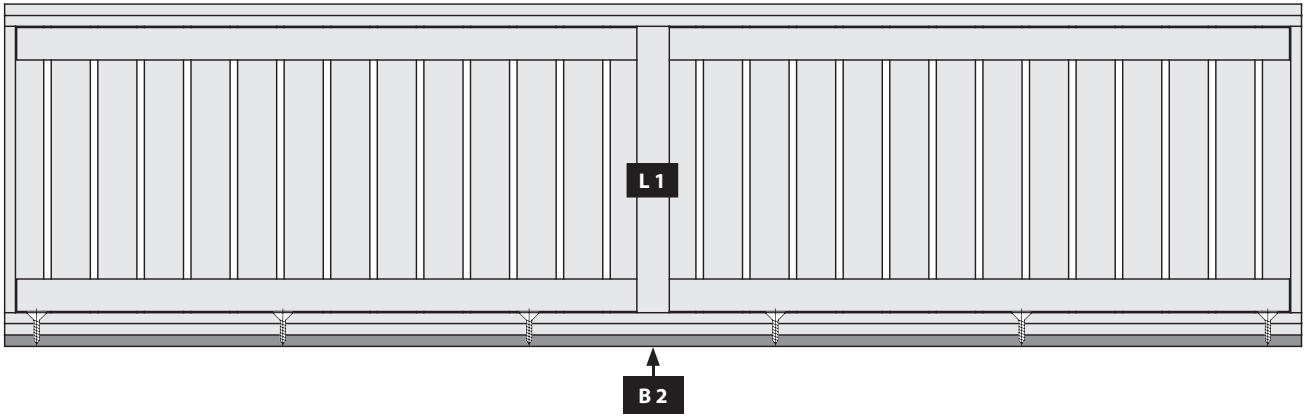
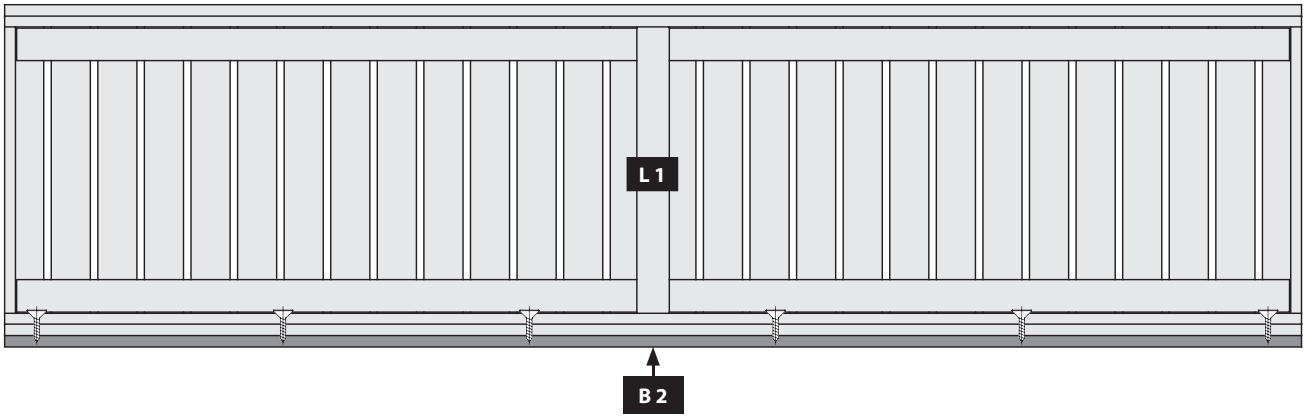
8x

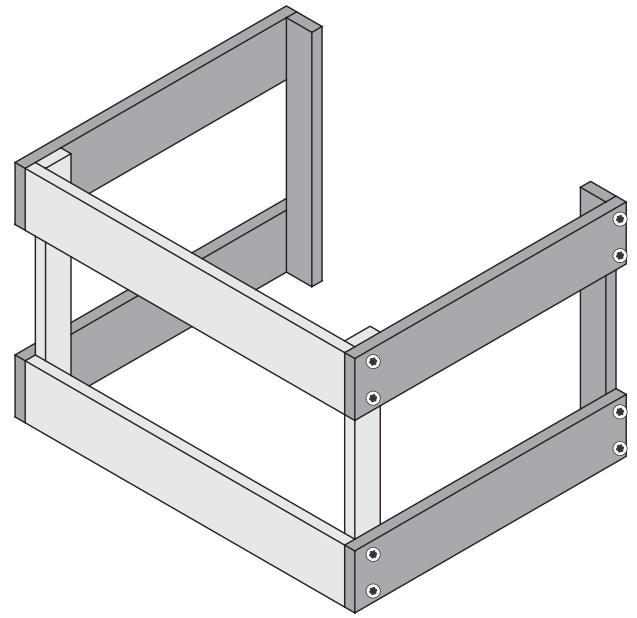
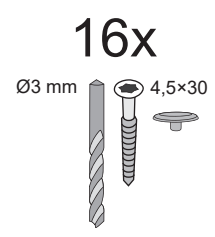
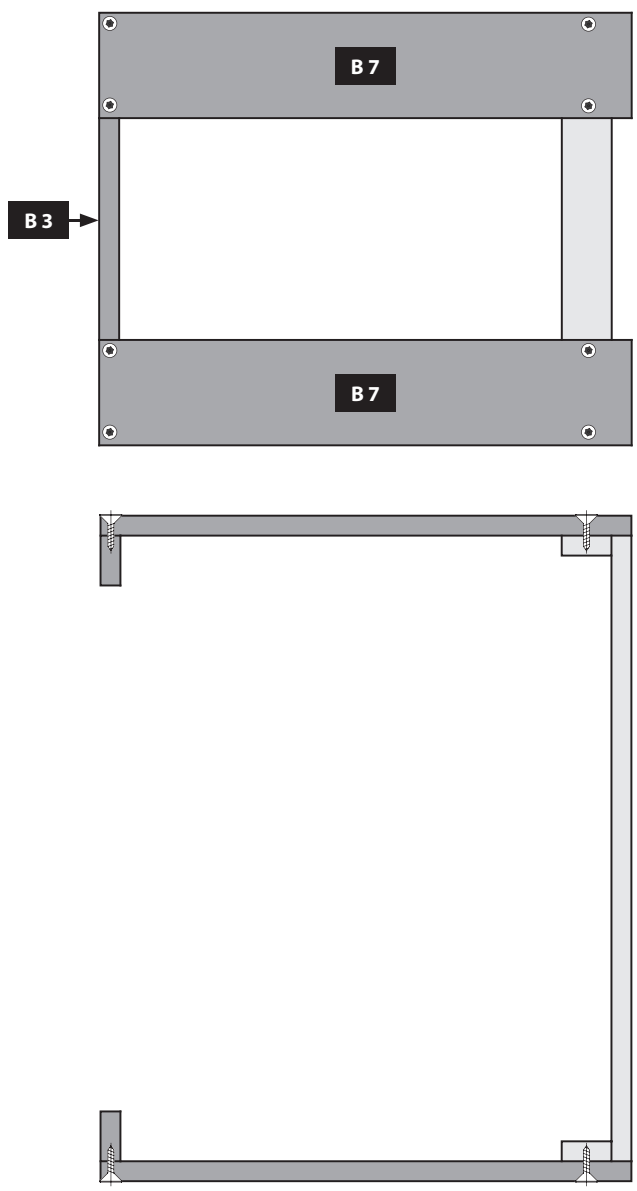
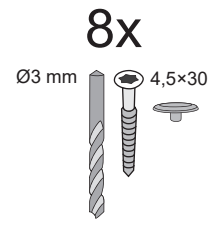
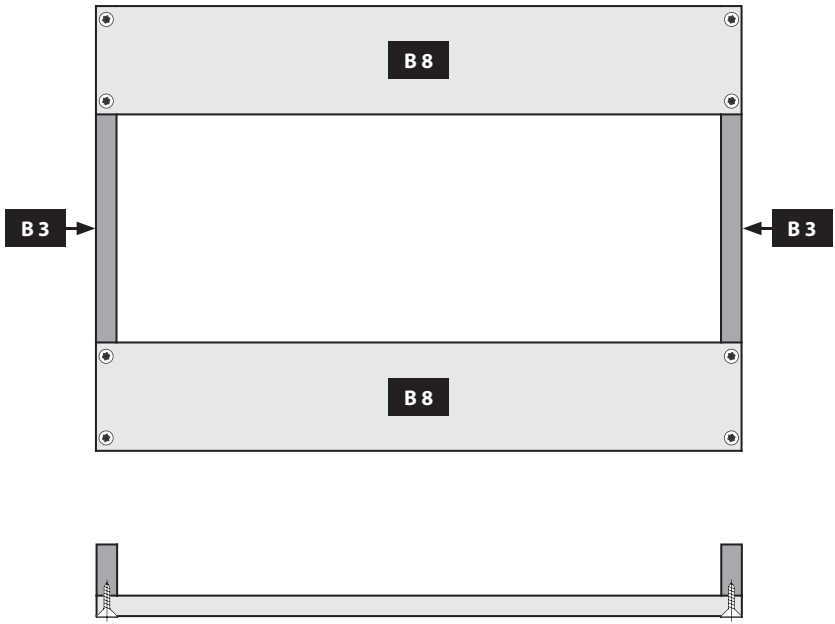











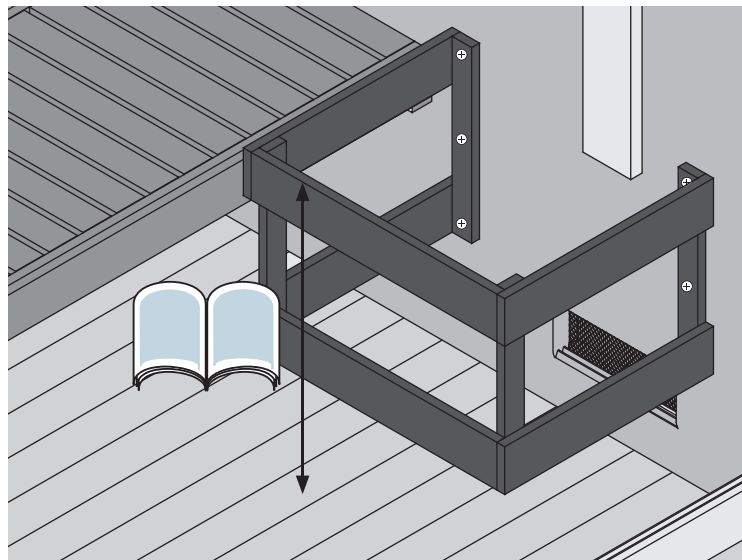
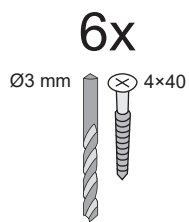
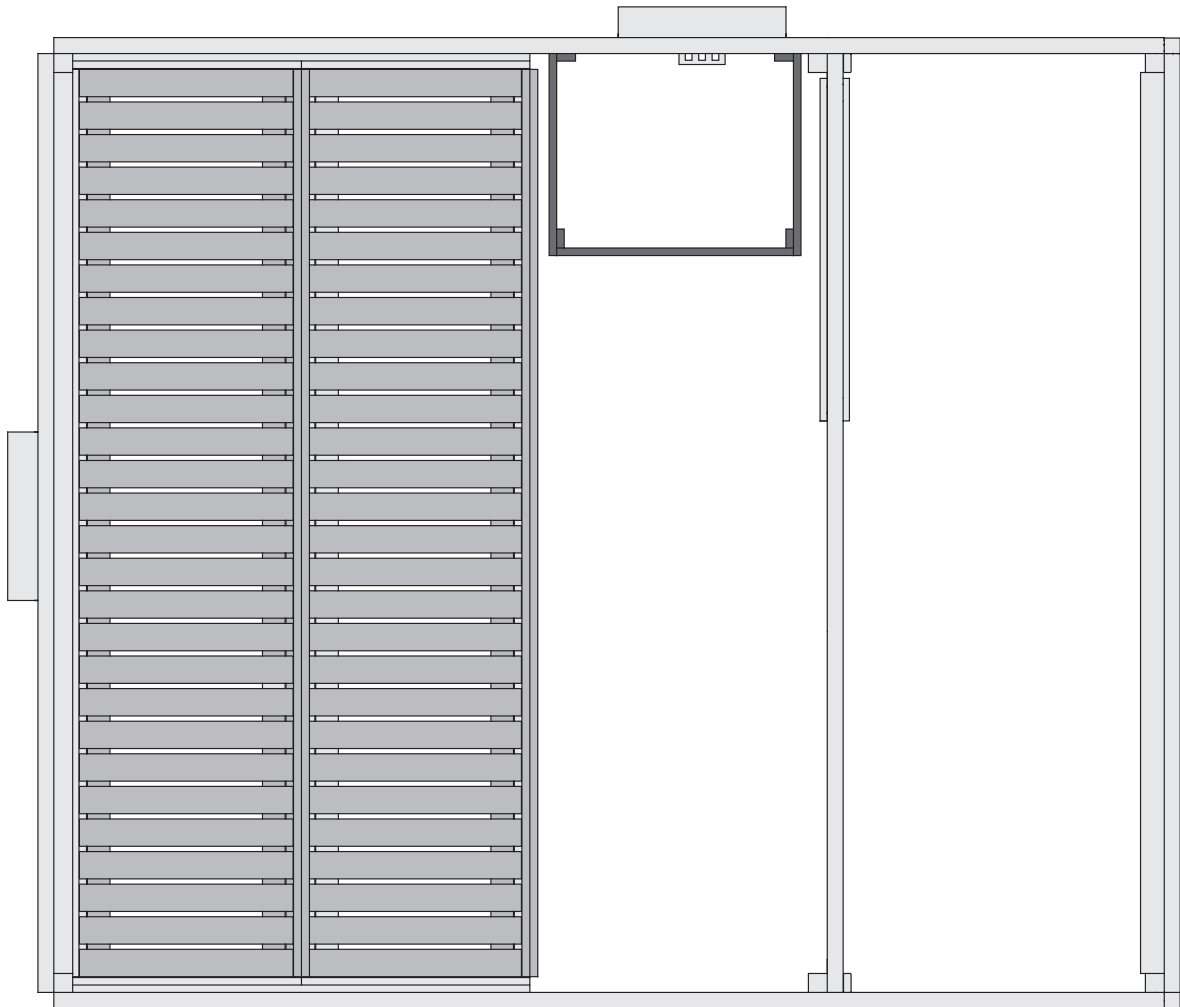

-  Höhe aus Ofenanleitung entnehmen
-  Take the height from the oven instructions
-  Prenez la hauteur des instructions du four
-  Neem de hoogte uit de oveninstructies

-  Tag højden fra ovnvejledningen
-  Tome la altura de las instrucciones del horno
-  Prendere l'altezza dalle istruzioni del forno
-  Výšku vezměte z návodu k troubě

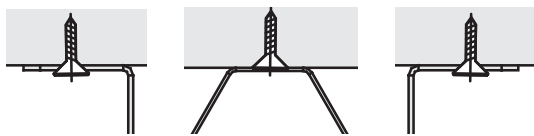



 Ofenbefestigung

 oven fixing

 fixation four

 oven vaststelling

 ovn fastsættelse

 fijación horno

 fissaggio forno

 upevňovací trouba

 Montáža peči

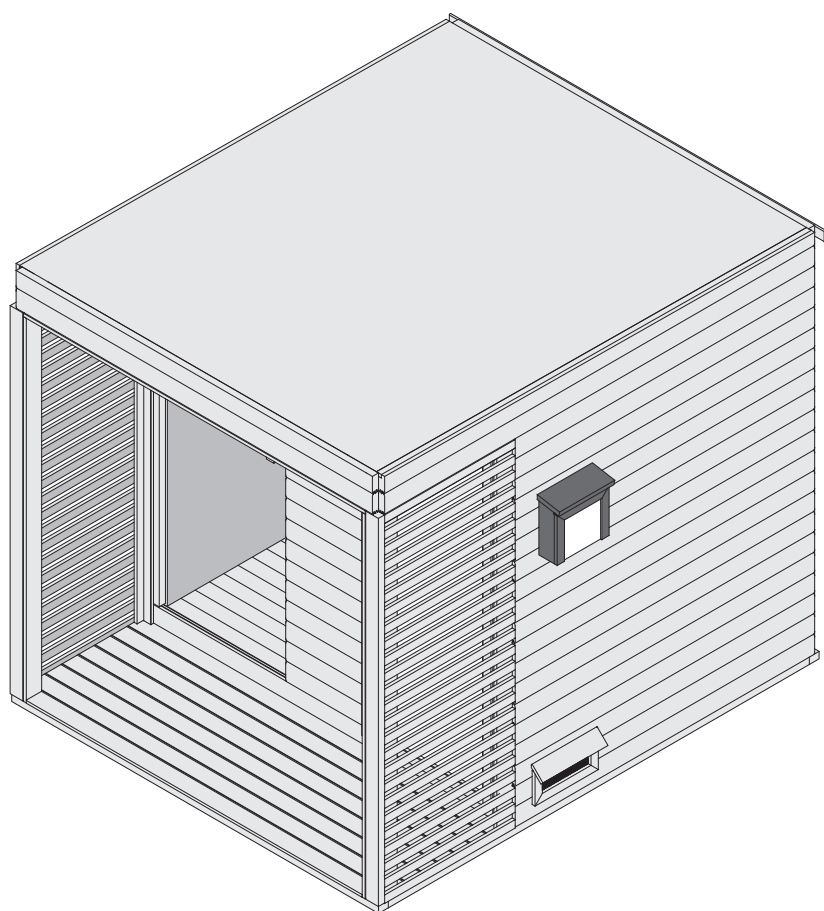
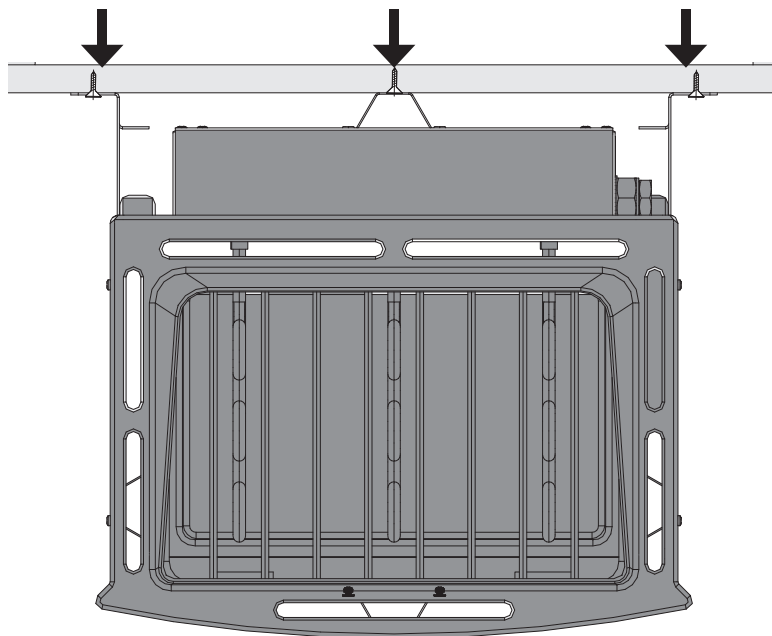

2x

Ø3 mm 4,5×60

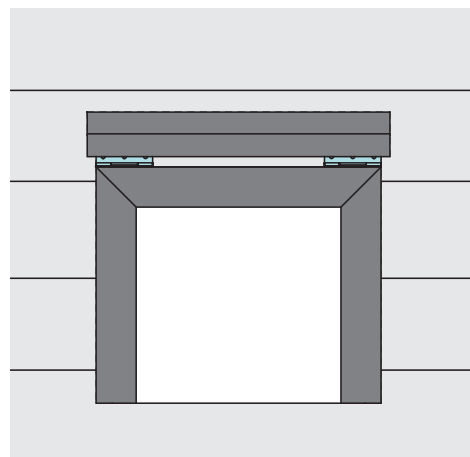
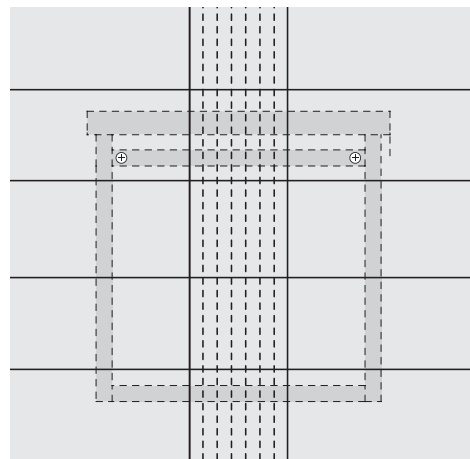
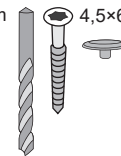

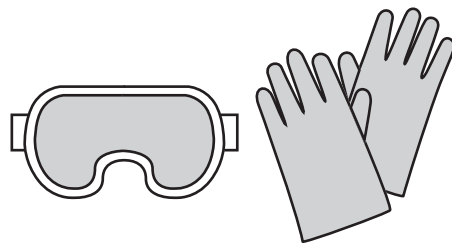

01

-  Tür in den Rahmen legen
-  Put the door in the frame
-  Mettez la porte dans le cadre
-  Plaats de deur in het frame
-  Sæt døren i rammen
-  Pon la puerta en el marco
-  Metti la porta nel telaio
-  Vložte dveře do rámu
-  Vrata namestite v okvir

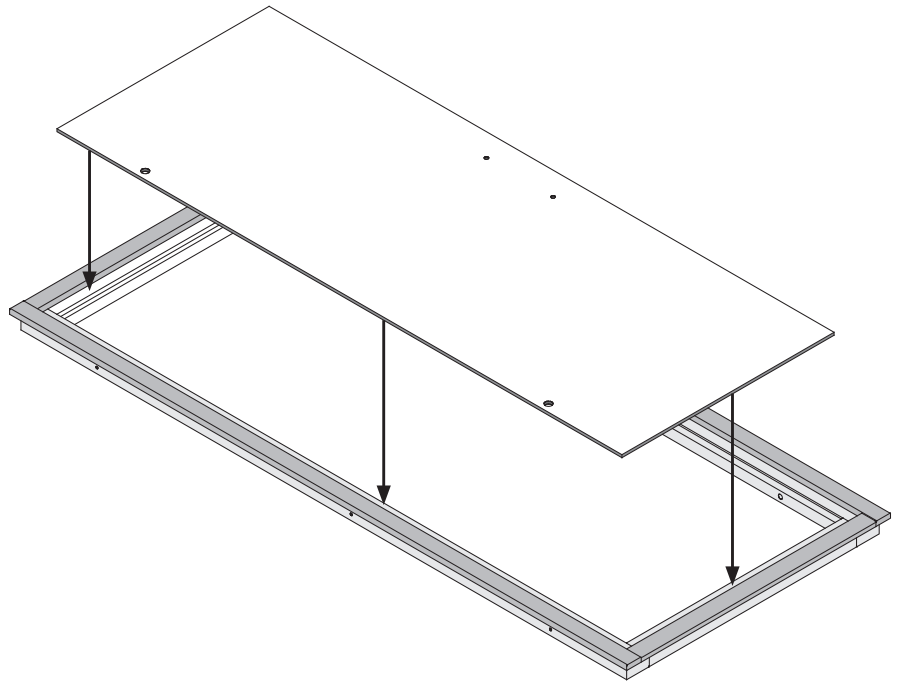

02

-  Tür im Rahmen ausrichten
-  Center the door in the frame
-  Aligner la porte dans le cadre
-  Lijn de deur in het frame uit
-  Juster døren i rammen
-  Alinea la puerta en el marco
-  Allinea la porta nella cornice
-  Zarovnejte dveře do rámu
-  Poravnajte vrata v okvir

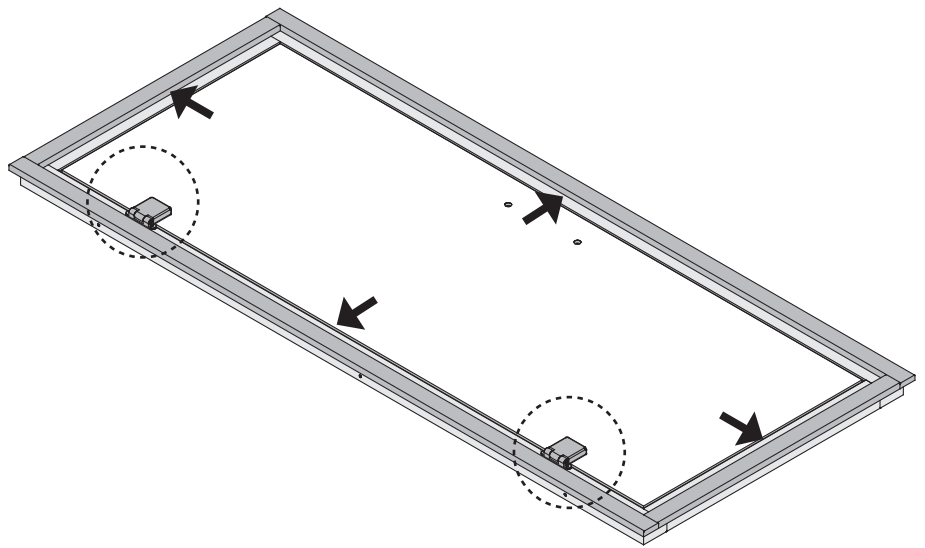

1.

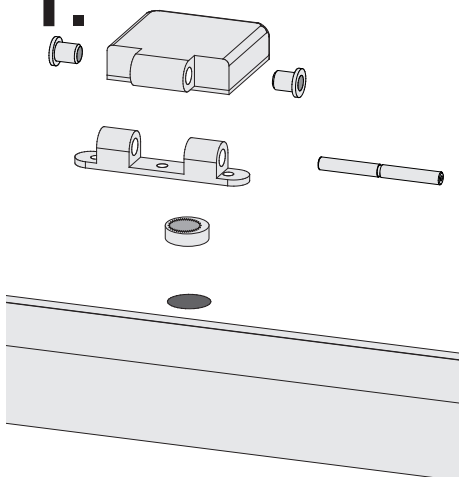

2.

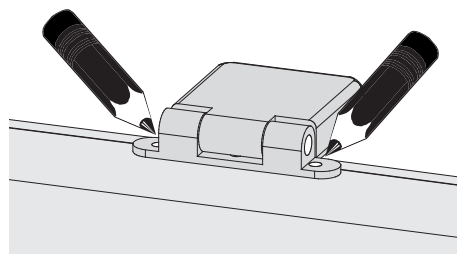

3.

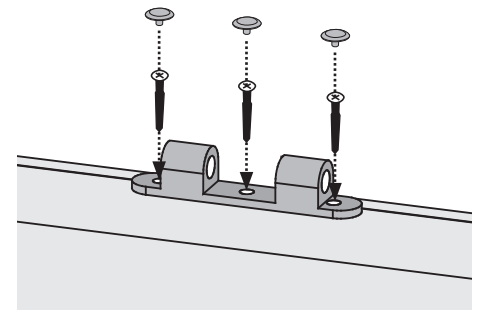

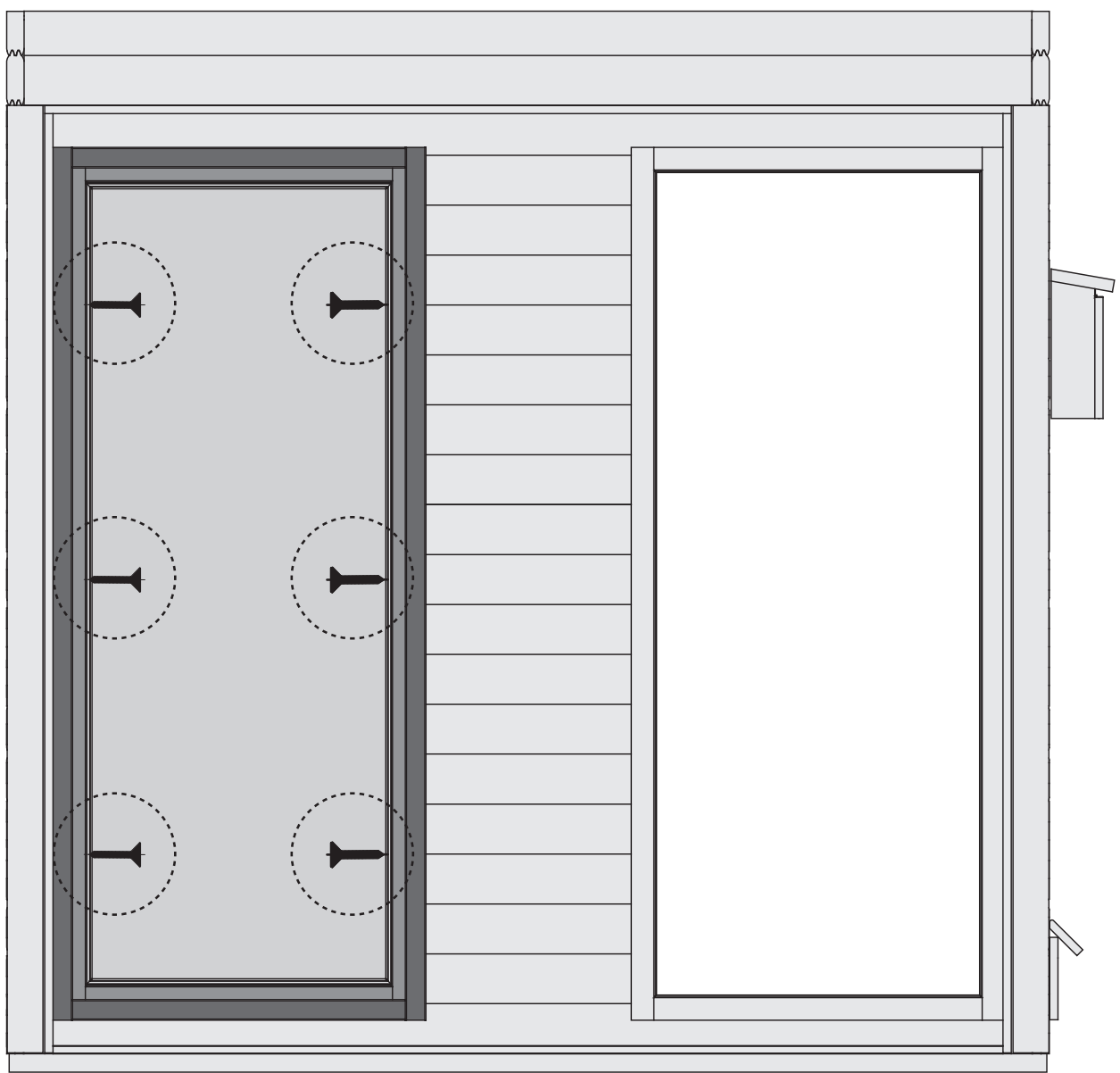
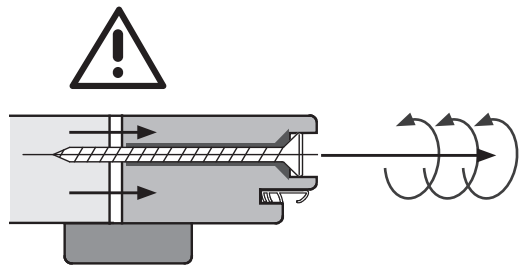
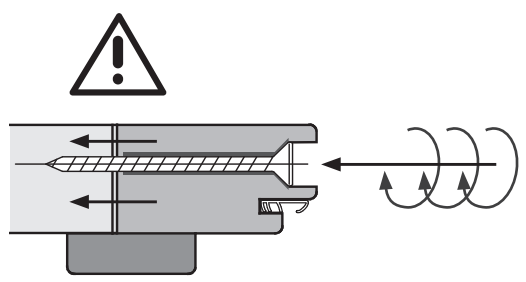
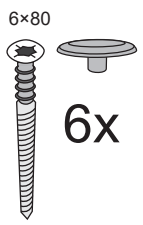

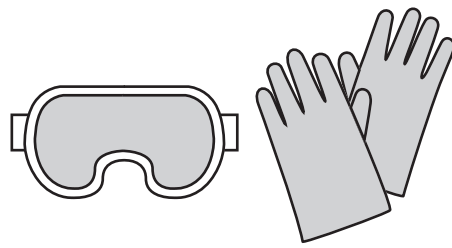



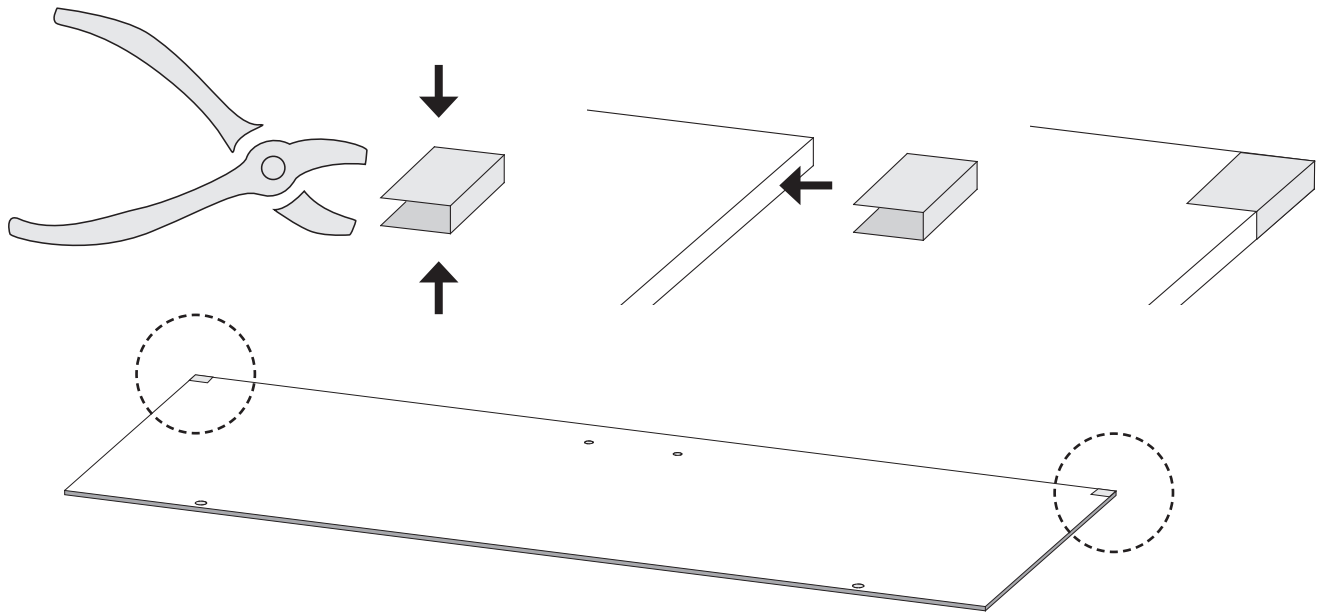





04



05

-  Alle Verstell-Excenter müssen in der Glasscheibe die gleiche Grundstellung haben
-  All adjustable eccentrics must have the same basic adjustment in the glass panel
-  Tous les excenteurs de positionnement doivent avoir la même position de base dans la vitre
-  Alle excentrische verstelelementen moeten in dezelfde stand in de glasplaat worden geplaatst
-  Alle justeringsexcentricer skal have samme grundlæggende position i glasruden
-  Todos los excéntricos regulables tienen que tener la misma posición base en la hoja de cristal
-  Tutti gli eccentrici di regolazione devono avere la stessa posizione base nella lastra di vetro
-  všechny nastavovací podivínů musí mít stejný základní polohy ve skle
-  Vsi nastavitveni ekscentri morajo imeti enak osnovni položaj v steklu.

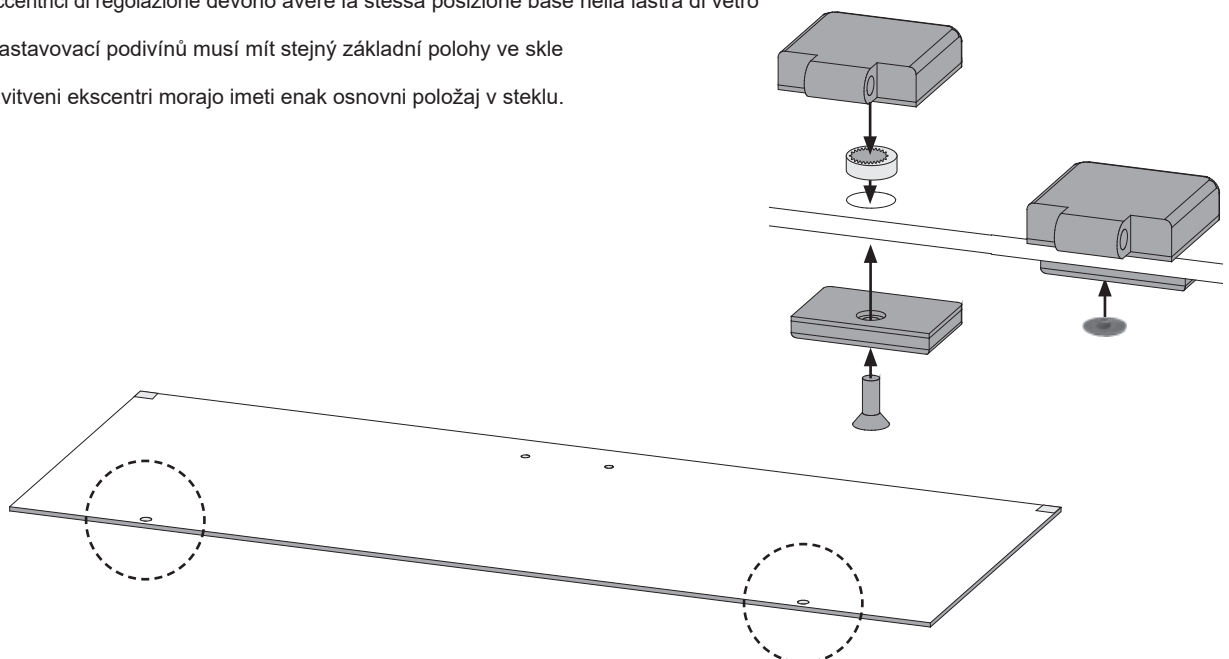

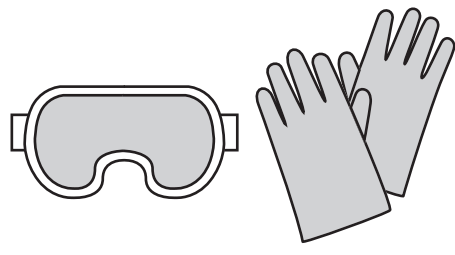

06

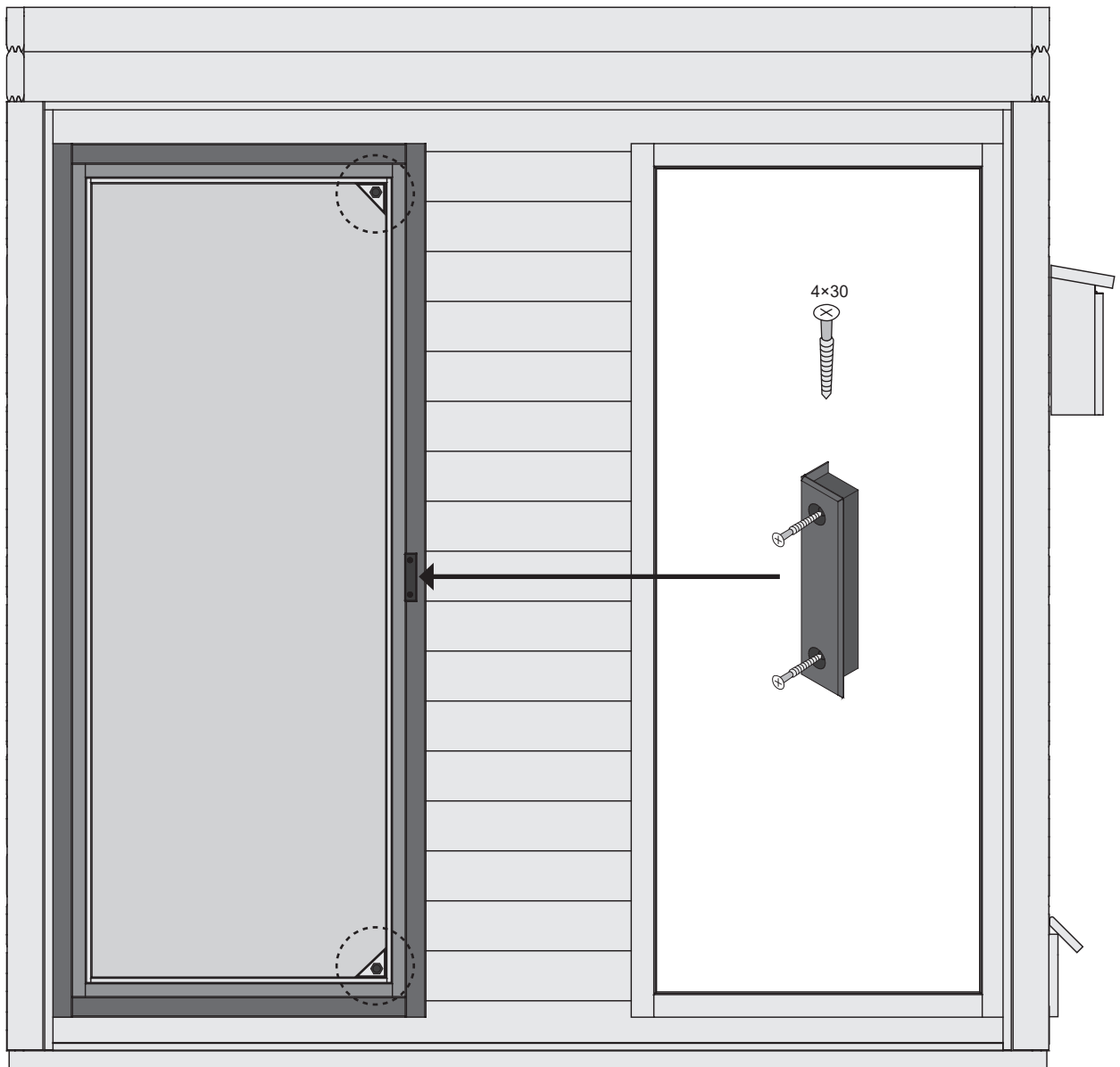

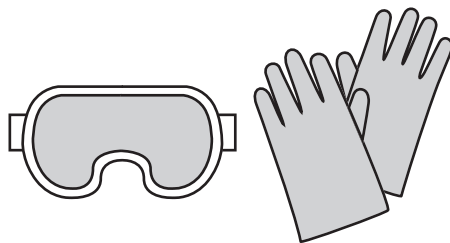

07



Alle Verstell-Excenter müssen in der Glasscheibe die gleiche Grundstellung haben



All adjustable eccentrics must have the same basic adjustment in the glass panel



Tous les excentreurs de positionnement doivent avoir la même position de base dans la vitre



Alle excentrische verstelelementen moeten in dezelfde stand in de glasplaat worden geplaatst



Alle justeringsexcentricer skal have samme grundlæggende position i glasruden



Todos los excéntricos regulables tienen que tener la misma posición base en la hoja de cristal



Tutti gli eccentrici di regolazione devono avere la stessa posizione base nella lastra di vetro



šechny nastavovací podivínů musí mít stejný základní polohy ve skle



Vsi nastavitveni ekscentri morajo imeti imeti enak osnovni položaj v steklu

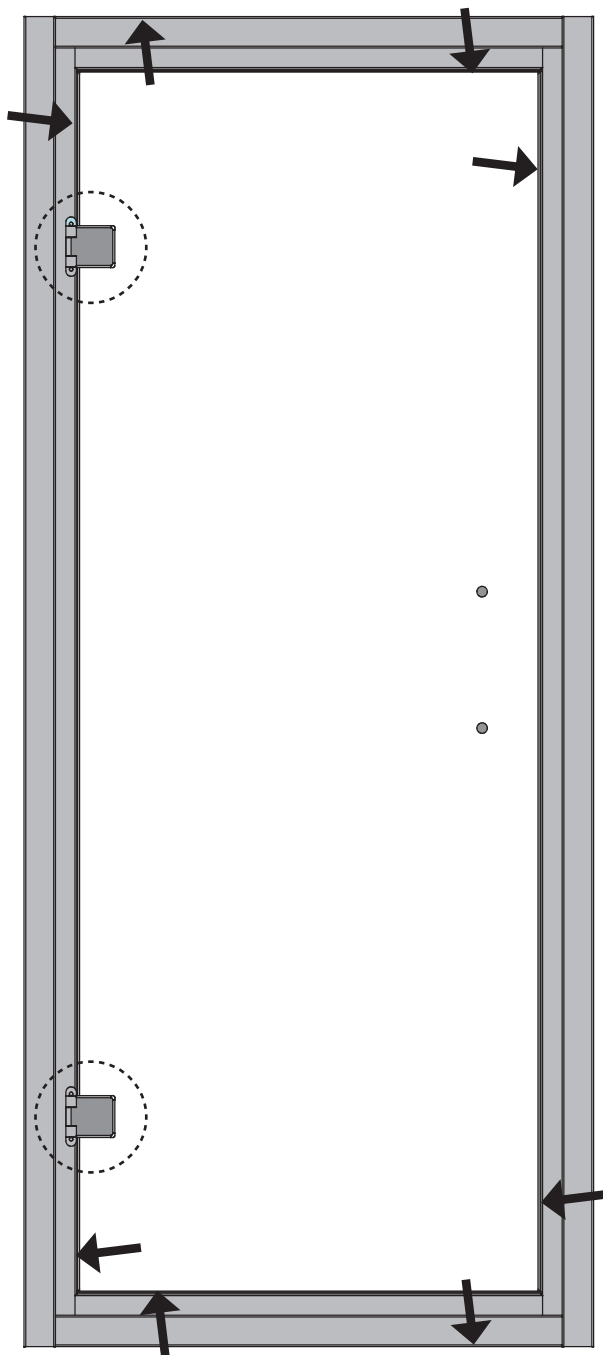
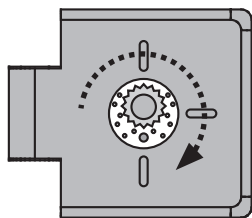
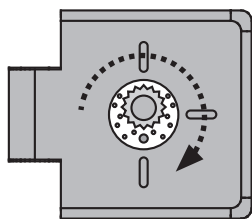
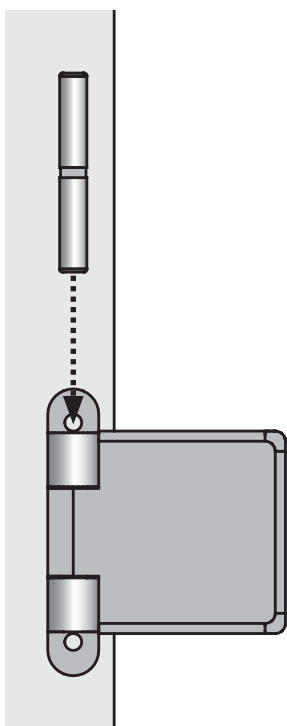

- | | | |
|---|-------------------|------------------|
|  | Außen: Metall | Innen: Holz |
|  | Outside: metal | Inside: wood |
|  | Extérieur: métal | Intérieur: bois |
|  | Buiten: metaal | Binnen: wood |
|  | Udenfor: metal | Inde: træ |
|  | Exterior: metal | Interior: madera |
|  | Esterno: metallo | Interno: legno |
|  | Venku: kov | Uvnitř: dřevo |
|  | Zunanjosť: kovina | Notranjosť: Les |

