

1x

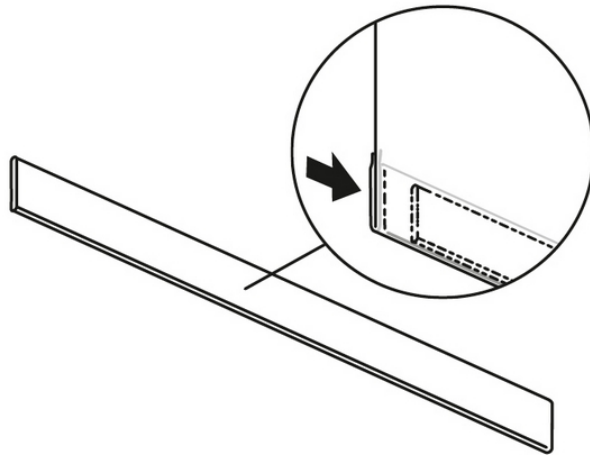

1x



2x